

# NPort S8000 Series

4-port device servers with managed Ethernet switch



## Features and Benefits

- 4-port RS-232/422/485 serial device server
- Serial QoS for configuring serial data transmission priority
- 2 kV isolation protection for each serial port (S8455I only)
- Adjustable pull high/low resistor for RS-485 ports (S8455I only)
- Built-in managed Ethernet switch
- S8455I fiber models: 2 fiber Ethernet ports and 3 Ethernet ports
- S8455I all-copper models: 5 Ethernet ports
- S8458 models: 4 fiber Ethernet ports and 4 Ethernet ports
- Ethernet redundancy with Turbo Ring and Turbo Chain (recovery time < 20 ms) or RSTP/STP (IEEE 802.1w/D) supported
- QoS, IGMP-snooping/GMRP, VLAN, LACP, SNMPv1/v2c/v3, RMON supported
- Surge protection for serial, Ethernet, and power

## Certifications



## Introduction

The NPort S8000 Series combines an industrial device server with a full-function managed Ethernet switch with 4 RS-232/422/485 serial ports, allowing you to easily install, manage, and maintain the product. Combining a device server and switch in one product allows you to save space in your cabinet, reduce overall power consumption, and reduce costs, since you will not need to purchase a switch and serial device server separately.

### Supports the Full Range of NPort 5000 Series Device Server Functions

The NPort S8000 Series supports the complete array of NPort 5000 device server functions. You can network your existing serial devices by connecting up to 4 serial devices through Ethernet ports, with only basic configuration required. In addition, data transmission between the serial and Ethernet interfaces is bidirectional.

### Full-Function Managed Ethernet Switch

The NPort S8000 Series has a built-in full-function managed Ethernet switch that supports QoS, IGMP-snooping/GMRP, VLAN, Port Trunking, SNMPv1/v2c/v3, and IEEE 802.1X, allowing you to handle virtually any kind of application. Ethernet redundancy, which is used to increase the reliability and availability of your industrial Ethernet network, is provided by Moxa's Turbo Ring and Turbo Chain technology (recovery time < 20 ms) or RSTP/STP (IEEE 802.1w/D).

### Ring Redundancy at the Device Level

Device-level communication networks for industrial automation are very critical since they are used to control and monitor device processes. The reliability of these communications depends on ring redundancy at the device level, which is designed to provide fast network fault detection and reconfiguration in order to support the most demanding control applications. The NPort S8000 Series integrates a full function NPort device server with an industrial switch to carry serial and Ethernet devices at the same time.

In addition, the NPort S8000 Series can also achieve ring redundancy with standard STP/RSTP and Moxa's proprietary Turbo Ring or Turbo Chain 2 redundancy protocols. This all-in-one design can be used to optimize and simplify your device network and enhance reliability.

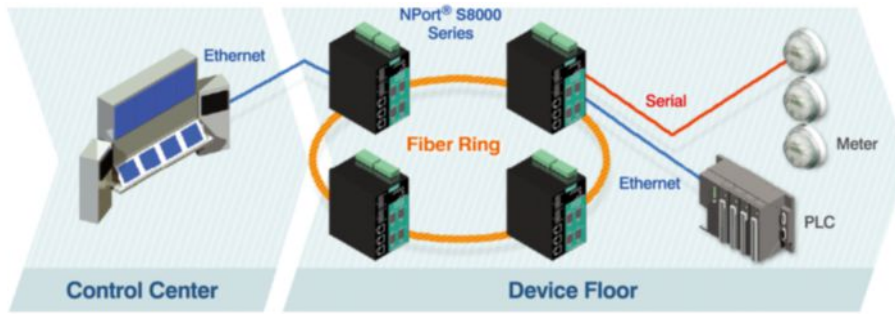

## Rugged Design with Complete Protection

The NPort S8000 Series complies with the UL 508 standard, which covers safety requirements for industrial control equipment. The NPort S8458 model supports high-level, 8/15 kV, ESD protection to prevent damage from static electricity. This model is also equipped with surge protection for power, Ethernet interface, and serial interface to protect against voltage spikes. With regard to the NPort S8455I, each serial port is protected by 2 kV isolation protection to guard against harmful currents.

## Appearance



## Specifications

### Input/Output Interface

Alarm Contact Channels	2, Resistive load: 1 A @ 24 VDC
Digital Input Channels	2
Digital Inputs	+13 to +30 V for state 1 -30 to +1 V for state 0 Max. input current: 8 mA

### Ethernet Interface

10/100BaseT(X) Ports (RJ45 connector)	NPort S8455I/S8455I-T: 5 NPort S8455I-MM-SC/SS-SC Series: 3 NPort S8458-4S-SC-T: 4
100BaseFX Ports (multi-mode SC connector)	NPort S8455I-MM-SC Series: 2
100BaseFX Ports (single-mode SC connector)	NPort S8455I-SS-SC Series: 2 NPort S8458-4S-SC-T: 4

### Optical Fiber

		100BaseFX		
		Multi-Mode		Single-Mode
Fiber Cable Type	OM1	50/125 $\mu\text{m}$	G.652	
		800 MHz x km		
Typical Distance		4 km	5 km	40 km
Wavelength	Typical (nm)		1300	1310
	TX Range (nm)		1260 to 1360	1280 to 1340

		100BaseFX		
		Multi-Mode		Single-Mode
		Fiber Cable Type	OM1	50/125 μm
			800 MHz x km	
	RX Range (nm)	1100 to 1600		1100 to 1600
Optical Power	TX Range (dBm)	-10 to -20		0 to -5
	RX Range (dBm)	-3 to -32		-3 to -34
	Link Budget (dB)	12		29
	Dispersion Penalty (dB)	3		1
<p>Note: When connecting a single-mode fiber transceiver, we recommend using an attenuator to prevent damage caused by excessive optical power.</p> <p>Note: Compute the “typical distance” of a specific fiber transceiver as follows: Link budget (dB) &gt; dispersion penalty (dB) + total link loss (dB).</p>				

Magnetic Isolation Protection	1.5 kV (built-in)
Standards	IEEE 802.1D-2004 for Spanning Tree Protocol IEEE 802.1p for Class of Service IEEE 802.1Q for VLAN Tagging IEEE 802.1w for Rapid Spanning Tree Protocol IEEE 802.1X for authentication IEEE 802.3 for 10BaseT IEEE 802.3ad for Port Trunk with LACP IEEE 802.3u for 100BaseT(X) and 100BaseFX IEEE 802.3x for flow control

#### Switch Properties

IGMP Groups	256
Max. No. of VLANs	64
Priority Queues	4
VLAN ID Range	VID 1 to 4094

#### Ethernet Software Features

Configuration Options	Web Console (HTTP/HTTPS), Windows Utility, Serial Console, Telnet Console
Management	BOOTP, Device Search Utility (DSU), DHCP Client, DHCP Option 82, HTTP, IPv4, LLDP, Port Mirror, RMON, SMTP, SNMPv1/v2c/v3, Syslog, TCP/IP, Telnet, Web Console
Filter	802.1Q, GVRP, IGMP v1/v2
Windows Real COM Drivers	Windows 95/98/ME/NT/2000, Windows XP/2003/Vista/2008/7/8/8.1/10 (x86/x64), Windows 2008 R2/2012/2012 R2 (x64), Windows Embedded CE 5.0/6.0, Windows XP Embedded
Linux Real TTY Drivers	Kernel version: 2.4.x, 2.6.x, 3.x, 4.x
Fixed TTY Drivers	SCO UNIX, SCO OpenServer, UnixWare 7, QNX 4.25, QNX 6, Solaris 10, FreeBSD, AIX 5.x, HP-UX 11i, Mac OS X
Android API	Android 3.1.x and later
Time Management	SNTP
MIB	Bridge MIB, Device Settings MIB, Ethernet-like MIB, MIB-II, P-BRIDGE MIB, Q-BRIDGE MIB, RFC1213, RFC1317, RMON MIB Groups 1, 2, 3, 9, RSTP MIB
Redundancy Protocols	RSTP, Turbo Chain, Turbo Ring v1, Turbo Ring v2

Security	HTTPS, SSL, SSH
Authentication	Local Account Accessibility RADIUS TACACS+

### Serial Interface

Connector	DB9 male
No. of Ports	4
Serial Standards	RS-232, RS-422, RS-485
Operation Modes	Disabled, Real COM mode, RFC2217 mode, TCP Client mode, TCP Server mode, UDP mode
Baudrate	50 bps to 921.6 kbps
Data Bits	5, 6, 7, 8
Stop Bits	1, 1.5, 2
Parity	None, Even, Odd, Space, Mark
Flow Control	None, RTS/CTS, XON/XOFF
Isolation	NPort S8455I Series: 2 kV
Surge	NPort S8458-4S-SC-T: 4 kV
RS-485 Data Direction Control	ADDC® (automatic data direction control)
Pull High/Low Resistor for RS-485	1 kilo-ohm, 150 kilo-ohms
Terminator for RS-485	120 ohms
Console Port	RS-232 (TxD, RxD, GND), 8-pin RJ45 (19200, n, 8, 1)

### Serial Signals

RS-232	TxD, RxD, RTS, CTS, DTR, DSR, DCD, GND
RS-422	Tx+, Tx-, Rx+, Rx-, GND
RS-485-4w	Tx+, Tx-, Rx+, Rx-, GND
RS-485-2w	Data+, Data-, GND

### DIP Switch Configuration

Ethernet Interface	Coupler, Master, Reserved, Turbo Ring
--------------------	---------------------------------------

### Power Parameters

No. of Power Inputs	2
Power Connector	2 removable 6-contact terminal block(s)
Input Current	NPort S8455I Series: 935 mA @ 12 VDC NPort S8458-4S-SC-T: 940 mA @ 12 VDC
Input Voltage	12 to 48 VDC

### Physical Characteristics

Housing	Metal
Dimensions	NPort S8455I Series: 73.1 x 134 x 125 mm (2.88 x 5.27 x 4.92 in)

	NPort S8458-4S-SC-T: 93 x 144 x 125 mm (3.66 x 5.64 x 4.92 in)
Weight	NPort S8455I Series: 578 g (1.27 lb) NPort S8458-4S-SC-T: 1105 g (2.44 lb)
Installation	DIN-rail mounting, Wall mounting (with optional kit)
<b>Environmental Limits</b>	
Operating Temperature	Standard Temp. Models: 0 to 60°C (32 to 140°F) NPort S8455I-T Series: -40 to 75°C (-40 to 167°F) NPort S8458-4S-SC-T: -40 to 85°C (-40 to 185°F)
Ambient Relative Humidity	5 to 95% (non-condensing)
<b>Standards and Certifications</b>	
EMC	EN 55032/24
EMI	CISPR 32, FCC Part 15B Class A
EMS	NPort S8455I Series: IEC 61000-4-2 ESD: Contact: 6 kV; Air: 8 kV IEC 61000-4-3 RS: 80 MHz to 1 GHz: 10 V/m IEC 61000-4-4 EFT: Signal: 1 kV IEC 61000-4-5 Surge: Power: 1 kV; Signal: 0.25 kV IEC 61000-4-6 CS: 150 kHz to 80 MHz: 10 V/m; Signal: 10 V/m IEC 61000-4-8  NPort S8458 Series: IEC 61000-4-2 ESD: Contact: 8 kV; Air: 15 kV IEC 61000-4-3 RS: 80 MHz to 1 GHz: 10 V/m IEC 61000-4-4 EFT: Power: 4 kV; Signal: 2 kV IEC 61000-4-5 Surge: Power: 4 kV; Signal: 4 kV IEC 61000-4-6 CS: 150 kHz to 80 MHz: 10 V/m; Signal: 10 V/m IEC 61000-4-8
Environmental Testing	IEC 60068-2-1 IEC 60068-2-3
Hazardous Locations	NPort S8455I Series: Class I Division 2
Safety	EN 60950-1, IEC 60950-1, UL 508, UL 60950-1
Shock	IEC 60068-2-27
Vibration	IEC 60068-2-6
<b>MTBF</b>	
Time	NPort S8455I/S8455I-T: 287,354 hrs NPort S8455I-MM-SC/MM-SC-T: 200,951 hrs NPort S8455I-SS-SC/SS-SC-T: 286,993 hrs NPort S8458-4S-SC-T: 163,624 hrs
Standards	Telcordia (Bellcore) Standard TR/SR
<b>Warranty</b>	
Warranty Period	5 years
Details	See <a href="http://www.moxa.com/warranty">www.moxa.com/warranty</a>
<b>Package Contents</b>	
Device	1 x NPort S8000 Series device server
Documentation	1 x document and software CD 1 x quick installation guide 1 x warranty card

# Dimensions

## NPort S8455I

Unit: mm (inch)

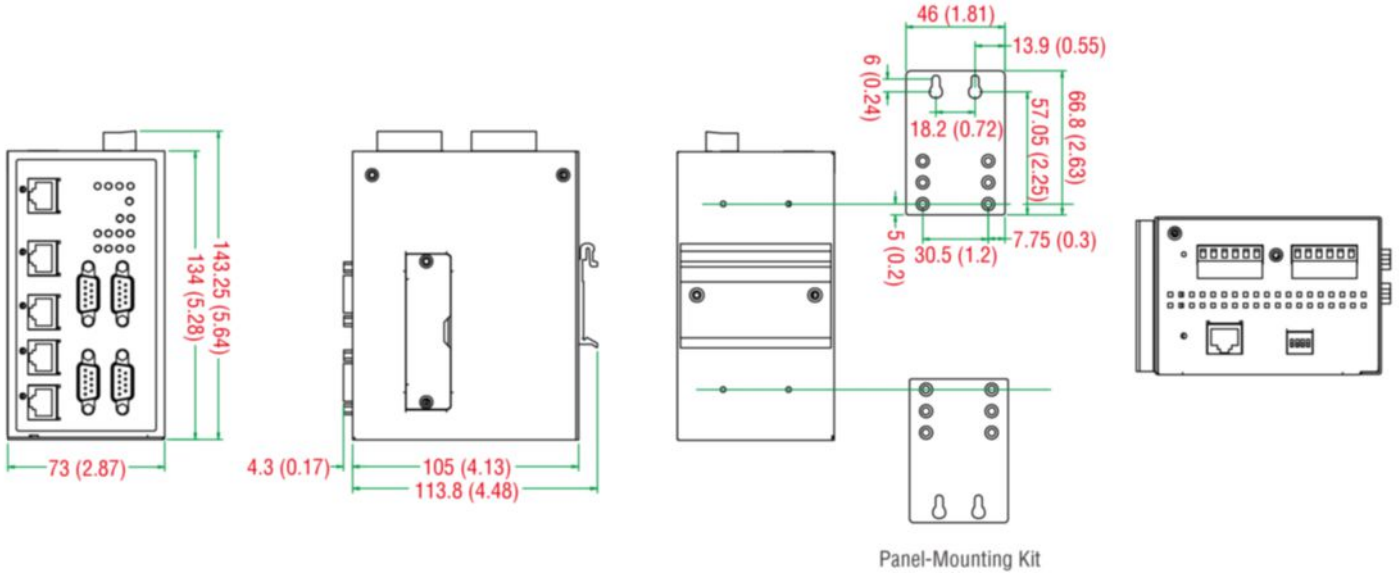

## NPort S8455I Fiber

Unit: mm (inch)

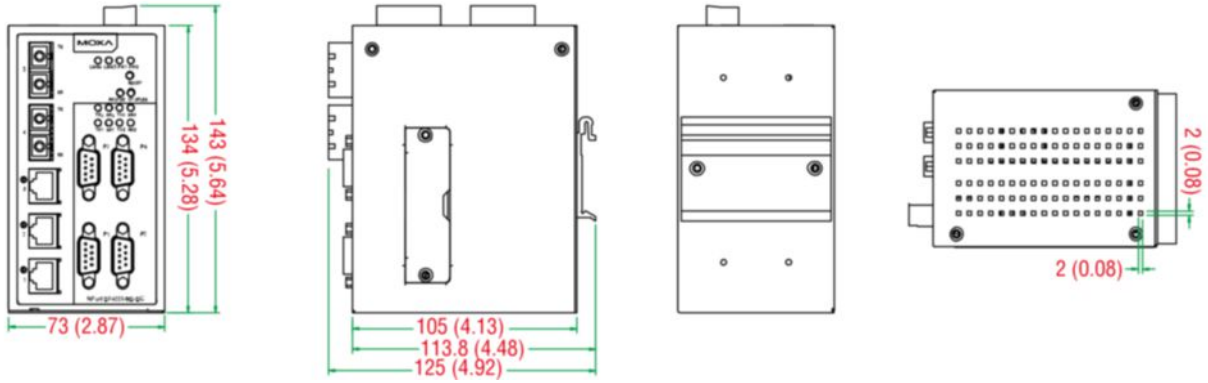

## NPort S8458

Unit: mm (inch)

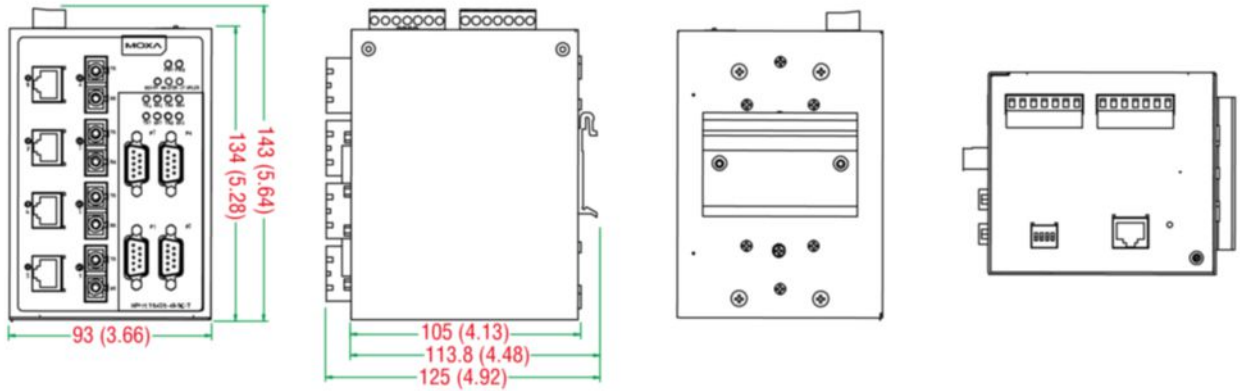

## Ordering Information

Model Name	10/100BaseT(X) Ports RJ45 Connector	100BaseFX Ports Multi-Mode SC Connector	100BaseFX Ports Single-Mode SC Connector	Operating Temp.	Input Voltage
NPort S8455I	5	–	–	0 to 60°C	12-48 VDC
NPort S8455I-T	5	–	–	-40 to 75°C	12-48 VDC
NPort S8455I-MM-SC	3	2	–	0 to 60°C	12-48 VDC
NPort S8455I-MM-SC-T	3	2	–	-40 to 75°C	12-48 VDC
NPort S8455I-SS-SC	3	–	2	0 to 60°C	12-48 VDC
NPort S8455I-SS-SC-T	3	–	2	-40 to 75°C	12-48 VDC
NPort S8458-4S-SC-T	4	–	4	-40 to 85°C	12-48 VDC

## Accessories (sold separately)

### Cables

CN20070	10-pin RJ45 to DB9 female serial cable, 1.5 m
CBL-F9M9-150	DB9 female to DB9 male serial cable, 1.5 m
CBL-F9M9-20	DB9 female to DB9 male serial cable, 20 cm

### Connectors

ADP-RJ458P-DB9F	DB9 female to RJ45 connector
Mini DB9F-to-TB	DB9 female to terminal block connector

### Power Cords

CBL-PJTB-10	Non-locking barrel plug to bare-wire cable
-------------	--

### Power Supplies

DR-4524	45W/2A DIN-rail 24 VDC power supply with universal 85 to 264 VAC or 120 to 370 VDC input, -10 to 50° C operating temperature
DR-75-24	75W/3.2A DIN-rail 24 VDC power supply with universal 85 to 264 VAC or 120 to 370 VDC input, -10 to 60°C operating temperature
DR-120-24	120W/2.5A DIN-rail 24 VDC power supply with universal 88 to 132 VAC or 176 to 264 VAC input by switch, or 248 to 370 VDC input, -10 to 60°C operating temperature

### Wall-Mounting Kits

WK-46	Wall-mounting kit, 2 plates, 8 screws, 46.5 x 66.8 x 1 mm
-------	---

© Moxa Inc. All rights reserved. Updated Jan 18, 2019.

This document and any portion thereof may not be reproduced or used in any manner whatsoever without the express written permission of Moxa Inc. Product specifications subject to change without notice. Visit our website for the most up-to-date product information.