

RS-232 to Fiber Converter

User's Guide

COPYRIGHT

All rights reserved. No part of this publication may be reproduced, stored in a retrieval system, or transmitted in any form or by any means, whether electronic, mechanical, photo copying, recording or otherwise, without the prior written permission of the publisher.

FCC WARNING

This equipment has been tested and found to comply with the limits for class A device, pursuant to part 15 of FCC rules. These limits are designed to provide reasonable protection against harmful interference in a commercial installation. This equipment generates, uses and can radiate radio frequency energy and, if not installed and used in accordance with the instructions, may cause harmful interference to radio communication. Operation of this equipment in a residential area is likely to cause harmful interference, in which case, the user will be required to correct the interference at the user's own expense.



CE

This is a Class A product. In a domestic environment, this product may cause radio interference in which case the user may be required to take adequate measures.



Take special note to read and understand all content giving in the warning boxes



Warning

TABLE OF CONTENTS

ABOUT THIS GUIDE	4
PURPOSE	4
TERMS/USAGE	4
INTRODUCTION	5
FEATURES	5
THE INDUSTRIAL CONVERTER UNPACKING AND SETUP	6
UNPACKING	6
LAYOUT OF THE CONVERTER	7
DIN RAIL MOUNTING OF THE CONVERTER.....	8
WALL MOUNTING THE CONVERTER	9
POWER INPUTS	9
FIBER CONNECTION	10
SERIAL CONNECTION	11
DTE AND DCE SWITCH SETTING	11
CONNECTION TO DATA TERMINAL EQUIPMENT (DTE).....	11
CONNECTION TO DATA COMMUNICATION EQUIPMENT (DCE)	12
LED INDICATORS	12
TECHNICAL SPECIFICATIONS	13
APPENDIX	14

ABOUT THIS GUIDE

Thank you for choosing RS-232 to Fiber Converter. This device integrates serial and multi-mode/single mode fiber networks in one flexible package.

The Industrial Series (RS-232 to Fiber) Converter provides a reliable and economical solution for your industrial Ethernet environment. The converter offers seamless integration while working as transparent device between your serial devices and industrial Ethernet. The Converter has operating temperature range from 0 to 50°C. Fiber enables you to extend the distances up to 120km.

Purpose

This guide discusses how to install the Industrial Series Converter.

Terms/Usage

In this guide, the term “**Converter**” (first letter upper case) refers to the RS-232 to Fiber Industrial Fast Ethernet Converter, and “**converter**” (first letter lower case) generically refers to all other Ethernet converters.

INTRODUCTION

This chapter describes the features and specification of the Converter.

Features

- Complies with EIA/TIA-232 & 574 standards
- Supports data transfer rate up to 115.20kbps
- Supports full duplex or half-duplex asynchronous data transmission
- Available with ST/SC connector for Multi-mode or SC connector for Single Mode
- Extends distance of up to 2km (6600 feet) multi-mode fiber and 120km (396000 feet) long-haul single mode fiber
- Push-button switch to select DTE & DCE
- LEDs for at-a-glance device status
- Suitable for industrial harsh environment
- Wide voltage range (9 ~ 32V DC)
- FCC Class A & CE approved

THE INDUSTRIAL CONVERTER UNPACKING AND SETUP

This section and the following sections explain the setup and installation of the Industrial Converter.

Unpacking

Open the box of the Converter and carefully unpack it. The box should contain the following items:

- ✓ *One RS-232 to Fiber Converter*
- ✓ *DIN rail bracket screws (optional)*
- ✓ *One AC power adaptor (please check connector type and input power specifications)*
- ✓ *DIN Rail Kit (Optional)*
- ✓ *Protective caps for unused ports*
- ✓ *This User's Guide*

If any item is found missing or damaged, please contact your local reseller for replacement.

Layout of the Converter

Front View of Converter

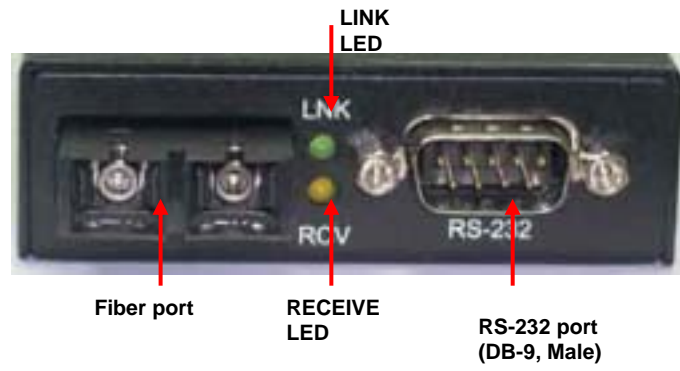

Rear View of Converter

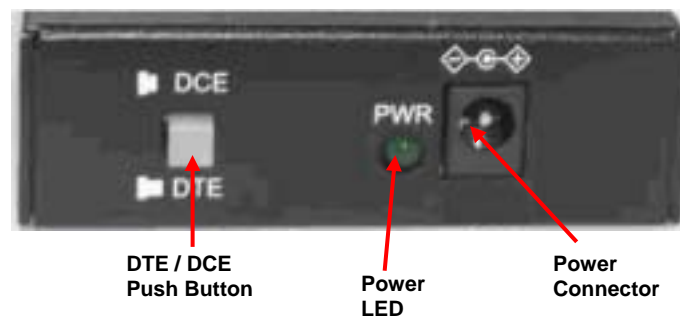

DIN Rail Mounting of the Converter

The aluminum DIN Rail attachment plate should already be affixed to the back panel of the Converter. If you need to attach the DIN Rail plate, assure that the stiff metal spring is situated towards the top. Attaching the Converter to the DIN rail is easy, just align, and attach the top rail, then press down and snap forward the Converter to snap in the bottom rail, as shown in the figures below.

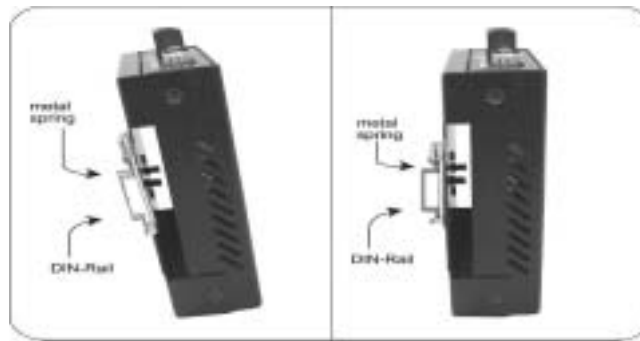

The setup of the Converter can be performed using the following steps:

- The surface must support at least 600 gm for the Converter.
- The power outlet should be within 1.82 meters (6 feet) of the Converter.

- Visually inspect the power adapter and make sure that it is properly connected.
- Make sure that there is proper heat dissipation from and adequate ventilation around the Converter. Do not place heavy objects on the Converter.

Wall Mounting the Converter

The Converter can also be installed by wall mounting. The backside casing provides space for two screws each side. Identify the exact location at wall by placing the Converter and marking the screw positions. Use the screw (include in the package) and snug them well to fix the Converter.

Power Inputs

Use the provided power adapter for power supply. Plug the power adapter's DC plug into the Converter's DC-IN jack and then power adapter into an electrical outlet.



Power Adapter: Only use the recommended specific

Power adapter provided with Converter. Check the technical specification section for information about the power input voltage.

Since the Converter does not include a power switch, plugging its power adapter into a power outlet will immediately power it on.

Fiber Connection

When connecting fiber cable to the Converter, be sure the correct type – ST or SC - connector is used. Follow the steps below to properly connect fiber cable:

1. Remove and keep the ST/SC port rubber covers. When not connected to a fiber cable, the rubber cover should be replaced to protect the optics.
2. Check that the fiber terminators are clean. You can clean the cable plugs by wiping them gently with a clean tissue or cotton ball moistened with a little ethanol. Dirty fiber terminators on fiber optic cables will impair the quality of the light transmitted through the cable and lead to degraded performance on the port.
3. Connect one end of the cable to the ST/SC port on the Converter and the other end to the ST/SC port on the other device.
4. Check the corresponding port LED on the Converter to be sure that the connection is valid. (Refer to the LED chart)



Warning Because invisible laser radiation may be emitted from the aperture of the port when no cable is connected, avoid exposure to laser radiation and do not stare into open apertures.

Serial Connection

Use the 9-pin female connector to connect the Converter to your DCE or DTE equipment. Use DTE/DCE push button accordingly.

DTE and DCE Switch Setting

The Converter features a push-button switch to set DTE or DCE mode. It alleviates the worry of cable type configuration when connecting the converter with a RS-232 device.

DTE mode
DCE mode

Connection to Data Terminal Equipment (DTE)

1. Set the push-button switch to DTE mode.
2. Prepare TIA/EIA-574 compliant straight through shielded cables with DB-9 connectors.
3. Connect one end of cable with female DB-9 connector to the Converter's male DB-9 connector.
4. Connect the other end of the cable with male or female DB-9 connector to another DTE's male or female DB-9 connector.

Note: The connectors will only fit male to female or

female to male connections.

Connection to Data Communication Equipment (DCE)

1. Set the push-button switch to DCE mode.
2. Prepare TIA/EIA-574 compliant straight-through cables with DB-9 connectors.
3. Connect one end of cable with female DB-9 connector to the Converter's male DB-9 connector.
4. Connect the other end of the cable with male or female DB-9 connector to another DCE's male or female DB-9 connector.

LED Indicators

The Converter has following LEDs.

Power Indicator (PWR): This LED lights green when the Converter is receiving power from input. It is located beside the power adapter pin.

RCV LED

Illuminates (green) to indicate when receiving data from a compliant device at serial port.

LNK LED

Illuminates to indicate receiving link pulses from a compliant device at fiber port.

TECHNICAL SPECIFICATIONS

General	
Standards	EIA/TIA-232, EIA/TIA-574
Connectors	1 x serial port (RS-232) 1 x ST/SC for multi-mode, SC for single mode
Wavelength	1310nm (multi-mode) 1310nm ~ 1550 (single mode)
Max Distances	RS-232 – 15 meters Fiber Optic – Up to 120,000 meters
Physical and Environmental	
Power Input	9-32V DC @ 800mA
Temperature	Operating: 0° ~ 50° C, Storage: -20° ~ 80° C
Humidity	Operating: 10% ~ 80%
Dimensions	109.20 x 90 x 31.50 mm (D x W x H)
Compliance	FCC Class A, CE approved

APPENDIX

RS-232 Pin Specification

Connector Outlook

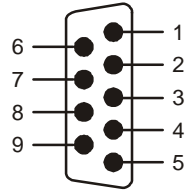

For your reference, the following diagram and tables show the RS-232 pin assignments.

RS-232 Connector pin assignment					
No	Code	Description	Signal Direction		Note
			DTE	DCE	
1	DCD	Data Carrier Detect	Out	Out	—
2	RX	Receive Data	Out	In	—
3	TX	Transmit Data	In	Out	—
4	DTR	Data Terminal Request	—	—	—
5	GND	Ground	—	—	—
6	DSR	Data Set Ready	—	—	—
7	RTS	Request to Send	—	—	—
8	CTS	Clear to Send	—	—	—
9	RI	Ring Indicator	—	—	—

- Note:
1. DTR and DSR Signals are connected together in PCB circuit
 2. RTS and CTS signals are connected together in PCB circuit
 3. RTS, CTS, DSR, DTR handshaking signals transmission are not available

