

# OPT1-ANT-5GSDWG-15

4× 5G NR MIMO/GNSS and 2× 2.4/5.0/6.0 GHz ISM MIMO Screw Mount

## Key Features

### Cable 1 - 4: 5G NR/GNSS

- 617-960 MHz
- 1175-1177 MHz
- 1427-2690 MHz
- 3300-5000 MHz
- 5150-5925 MHz

### Cable 5 - 6: 2.4/5.0/6.0 GHz ISM

- 2410-2490 MHz
- 4920-7125 MHz

Screw Mount

High Performance

Ground Plane Independent

Dimensions: 199 × 167 × 53 mm

Certificates: IP67, IP69

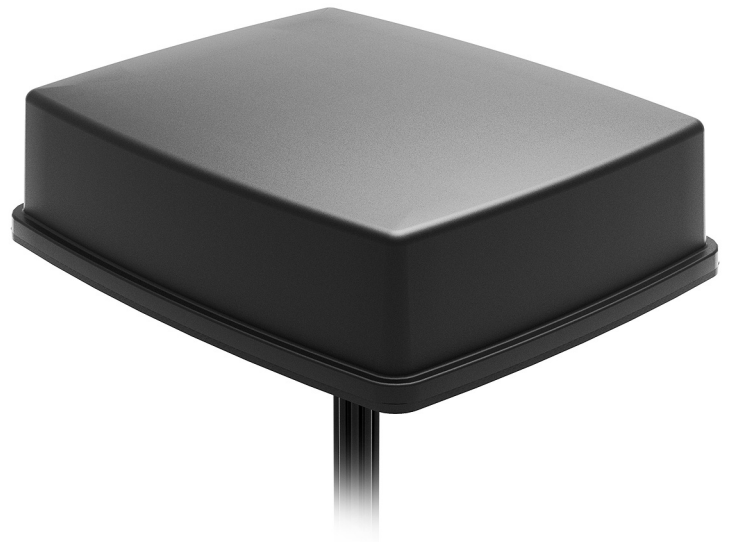

## 1. Antenna and electrical specifications

Cable 1

Parameters	5G NR Antenna				
Technologies	5G, 4G, 3G and 2G, GNSS				
Standards	5G NR/4G LTE/FirstNet/CBRS/LPWA/CAT-X/CAT-Mx/CAT-NBx/NB-IoT/3G/2G				
Frequency (MHz)	617-960	1175-1177	1427-2690	3300-5000	5150-5925
Band (MHz)	600, 700, 850, 900		1500, 1600, 1700, 1800, 1900, 2000, 2100, 2300, 2500, 2600	3300, 3500, 3600, 3700, 4500	5200, 5500, 5800
5G NR Bands	n5, n8, 12, n20, n28, n71, n81, n82, n83,		n1, n2, n3, n7, n25, n34, n38, n39, n40, n41, n50, n51, n66, n70, n74, n75, n76, n80, n84, n86	n77, n78, n79	
4G LTE Bands	B5, B6, B8, B12, B13, B14, B17, B18, B19, B20, B26, B27, B28, B29, B44, B67, B68, B71, B85		B1, B2, B3, B4, B7, B9, B10, B11, B21, B23, B24, B25, B30, B32, B33, B34, B35, B36, B37, B38, B39, B40, B41, B45, B50, B51, B65, B66, B69, B70, B74, B75, B76	B22, B42, B43, B48, B49, B52	B46, B47, B252, B255
3G CELL Bands	B5, B6, B8, B12, B13, B14, B19, B20, B26		B1, B2, B3, B4, B7, B9, B10, B11, B21, B25, B32, B33, B34, B35, B36, B37, B38, B39, B40	B22	
2G CELL Bands	710, 750, 810T, 850, 900P, 900E, 900R		1800DCS, 1900PCS		
CDMA CELL Bands	BC0, BC2, BC3, BC7, BC9, BC10, BC12, BC18, BC19		BC1, BC4, BC6, BC8, BC13, BC14, BC15, BC16, BC20, BC21		
GNSS Bands		GPS(L5), BeiDou(B2a), QZSS(L5), Galileo(E5a), IRNSS(L5)	GPS(L1C), GLONAS(L1OF), BeiDou(B1), QZSS(L1C), Galileo(E1)		
Return Loss (dB)	~-8.1	~-5.73	~-16.1	~-19.9	~-12.5
VSWR	~1.9:1	~3.1:1	~1.5:1	~1.3:1	~1.5:1
Efficiency (%)	~37.4	~31.5	~45.2	~47.0	~37.4
Peak Gain (dBi)	~3.0	~2.2	~5.1	~5.9	~5.6
Average Gain (dB)	~-3.9	~-2.9	~-3.3	~-2.8	~-3.7
Impedance (Ohm)			50		
Polarisation			Linear		
Radiation Pattern			Omni-Directional		
Max. Input Power (W)			25		
Connector Type			SMA-Male		
Cable Length			150 cm		
Cable Type			D302		

**Cable 2**

Parameters	5G NR Antenna				
Technologies	5G, 4G, 3G and 2G, GNSS				
Standards	5G NR/4G LTE/FirstNet/CBRS/LPWA/CAT-X/CAT-Mx/CAT-NBx/NB-IoT/3G/2G				
Frequency (MHz)	617-960	1175-1177	1427-2690	3300-5000	5150-5925
Band (MHz)	600, 700, 850, 900		1500, 1600, 1700, 1800, 1900, 2000, 2100, 2300, 2500, 2600	3300, 3500, 3600, 3700, 4500	5200, 5500, 5800
5G NR Bands	n5, n8, 12, n20, n28, n71, n81, n82, n83,		n1, n2, n3, n7, n25, n34, n38, n39, n40, n41, n50, n51, n66, n70, n74, n75, n76, n80, n84, n86	n77, n78, n79	
4G LTE Bands	B5, B6, B8, B12, B13, B14, B17, B18, B19, B20, B26, B27, B28, B29, B44, B67, B68, B71, B85		B1, B2, B3, B4, B7, B9, B10, B11, B21, B23, B24, B25, B30, B32, B33, B34, B35, B36, B37, B38, B39, B40, B41, B45, B50, B51, B65, B66, B69, B70, B74, B75, B76	B22, B42, B43, B48, B49, B52	B46, B47, B252, B255
3G CELL Bands	B5, B6, B8, B12, B13, B14, B19, B20, B26		B1, B2, B3, B4, B7, B9, B10, B11, B21, B25, B32, B33, B34, B35, B36, B37, B38, B39, B40	B22	
2G CELL Bands	710, 750, 810T, 850, 900P, 900E, 900R		1800DCS, 1900PCS		
CDMA CELL Bands	BC0, BC2, BC3, BC7, BC9, BC10, BC12, BC18, BC19		BC1, BC4, BC6, BC8, BC13, BC14, BC15, BC16, BC20, BC21		
GNSS Bands		GPS(L5), BeiDou(B2a), QZSS(L5), Galileo(E5a), IRNSS(L5)	GPS(L1C), GLONAS(L1OF), BeiDou(B1), QZSS(L1C), Galileo(E1)		
Return Loss (dB)	~-9.8	~-6.1	~-14.2	~-18.9	~-12.8
VSWR	~1.9:1	~3.0:1	~1.6:1	~1.2:1	~1.6:1
Efficiency (%)	~33.2	~27.6	~48.3	~49.5	~37.5
Peak Gain (dBi)	~1.6	~2.1	~5.4	~6.0	~5.3
Average Gain (dB)	~-4.4	~-3.2	~-2.9	~-2.6	~-3.7
Impedance (Ohm)			50		
Polarisation			Linear		
Radiation Pattern			Omni-Directional		
Max. Input Power (W)			25		
Connector Type			SMA-Male		
Cable Length			150 cm		
Cable Type			D302		

**Cable 3**

Parameters	5G NR Antenna				
Technologies	5G, 4G, 3G and 2G, GNSS				
Standards	5G NR/4G LTE/FirstNet/CBRS/LPWA/CAT-X/CAT-Mx/CAT-NBx/NB-IoT/3G/2G				
Frequency (MHz)	617-960	1175-1177	1427-2690	3300-5000	5150-5925
Band (MHz)	600, 700, 850, 900		1500, 1600, 1700, 1800, 1900, 2000, 2100, 2300, 2500, 2600	3300, 3500, 3600, 3700, 4500	5200, 5500, 5800
5G NR Bands	n5, n8, 12, n20, n28, n71, n81, n82, n83,		n1, n2, n3, n7, n25, n34, n38, n39, n40, n41, n50, n51, n66, n70, n74, n75, n76, n80, n84, n86	n77, n78, n79	
4G LTE Bands	B5, B6, B8, B12, B13, B14, B17, B18, B19, B20, B26, B27, B28, B29, B44, B67, B68, B71, B85		B1, B2, B3, B4, B7, B9, B10, B11, B21, B23, B24, B25, B30, B32, B33, B34, B35, B36, B37, B38, B39, B40, B41, B45, B50, B51, B65, B66, B69, B70, B74, B75, B76	B22, B42, B43, B48, B49, B52	B46, B47, B252, B255
3G CELL Bands	B5, B6, B8, B12, B13, B14, B19, B20, B26		B1, B2, B3, B4, B7, B9, B10, B11, B21, B25, B32, B33, B34, B35, B36, B37, B38, B39, B40	B22	
2G CELL Bands	710, 750, 810T, 850, 900P, 900E, 900R		1800DCS, 1900PCS		
CDMA CELL Bands	BC0, BC2, BC3, BC7, BC9, BC10, BC12, BC18, BC19		BC1, BC4, BC6, BC8, BC13, BC14, BC15, BC16, BC20, BC21		
GNSS Bands		GPS(L5), BeiDou(B2a), QZSS(L5), Galileo(E5a), IRNSS(L5)	GPS(L1C), GLONAS(L1OF), BeiDou(B1), QZSS(L1C), Galileo(E1)		
Return Loss (dB)	~-10.5	~-5.3	~-11.6	~-18.0	~-13.2
VSWR	~1.6:1	~3.2:1	~1.7:1	~1.4:1	~1.6:1
Efficiency (%)	~36.6	~31.9	~54.4	~50.4	~40.2
Peak Gain (dBi)	~2.6	~2.5	~6.0	~6.0	~5.5
Average Gain (dB)	~-4.0	~-2.7	~-2.5	~-2.5	~-3.4
Impedance (Ohm)			50		
Polarisation			Linear		
Radiation Pattern			Omni-Directional		
Max. Input Power (W)			25		
Connector Type			SMA-Male		
Cable Length			150 cm		
Cable Type			D302		

**Cable 4**

Parameters	5G NR Antenna				
Technologies	5G, 4G, 3G and 2G, GNSS				
Standards	5G NR/4G LTE/FirstNet/CBRS/LPWA/CAT-X/CAT-Mx/CAT-NBx/NB-IoT/3G/2G				
Frequency (MHz)	617-960	1175-1177	1427-2690	3300-5000	5150-5925
Band (MHz)	600, 700, 850, 900		1500, 1600, 1700, 1800, 1900, 2000, 2100, 2300, 2500, 2600	3300, 3500, 3600, 3700, 4500	5200, 5500, 5800
5G NR Bands	n5, n8, 12, n20, n28, n71, n81, n82, n83,		n1, n2, n3, n7, n25, n34, n38, n39, n40, n41, n50, n51, n66, n70, n74, n75, n76, n80, n84, n86	n77, n78, n79	
4G LTE Bands	B5, B6, B8, B12, B13, B14, B17, B18, B19, B20, B26, B27, B28, B29, B44, B67, B68, B71, B85		B1, B2, B3, B4, B7, B9, B10, B11, B21, B23, B24, B25, B30, B32, B33, B34, B35, B36, B37, B38, B39, B40, B41, B45, B50, B51, B65, B66, B69, B70, B74, B75, B76	B22, B42, B43, B48, B49, B52	B46, B47, B252, B255
3G CELL Bands	B5, B6, B8, B12, B13, B14, B19, B20, B26		B1, B2, B3, B4, B7, B9, B10, B11, B21, B25, B32, B33, B34, B35, B36, B37, B38, B39, B40	B22	
2G CELL Bands	710, 750, 810T, 850, 900P, 900E, 900R		1800DCS, 1900PCS		
CDMA CELL Bands	BC0, BC2, BC3, BC7, BC9, BC10, BC12, BC18, BC19		BC1, BC4, BC6, BC8, BC13, BC14, BC15, BC16, BC20, BC21		
GNSS Bands		GPS(L5), BeiDou(B2a), QZSS(L5), Galileo(E5a), IRNSS(L5)	GPS(L1C), GLONAS(L1OF), BeiDou(B1), QZSS(L1C), Galileo(E1)		
Return Loss (dB)	~-9.5	~-5.3	~-13.7	~-19.1	~-10.4
VSWR	~1.7:1	~3.4:1	~1.7:1	~1.2:1	~1.7:1
Efficiency (%)	~36.1	~29.7	~54.3	~49.9	~38.8
Peak Gain (dBi)	~3.4	~2.4	~5.7	~6.0	~5.6
Average Gain (dB)	~-3.9	~-3.1	~-2.5	~-2.7	~-3.6
Impedance (Ohm)			50		
Polarisation			Linear		
Radiation Pattern			Omni-Directional		
Max. Input Power (W)			25		
Connector Type			SMA-Male		
Cable Length			150 cm		
Cable Type			D302		

**Antenna Measurement Conditions:**

Mounted on Metal Plate of 30 x 30 cm, 100 cm of Cable D302, Measured in Certified CTIA 3D Anechoic Chamber

**Cable 5**

Parameters	2.4/5.0/6.0 GHz ISM Antenna		
Standards	WiFi, BT, ZigBee, ISM, Sigfox, LoRa		
Band (MHz)	2.4GHz	5.0 GHz	6.0GHz
Frequency (MHz)	2410-2490	4920-5925	5925-7125
Return Loss (dB)	~-13.9	~-23.7	~-14.1
VSWR	~1.5:1	~1.2:1	~1.5:1
Efficiency (%)	~55.6	~51.9	~37.5
Peak Gain (dBi)	~-4.3	~-6.7	~-6.3
Average Gain (dB)	~-2.6	~-2.8	~-3.2
Impedance (Ohm)	50		
Polarisation	Linear		
Radiation Pattern	Omni-Directional		
Max. Input Power (W)	25		
Connector Type	SMA-Male-RP		
Cable Length	150 cm		
Cable Type	D302		

**Cable 6**

Parameters	2.4/5.0/6.0 GHz ISM Antenna		
Standards	WiFi, BT, ZigBee, ISM, Sigfox, LoRa		
Band (MHz)	2.4 GHz	5.0 GHz	6.0 GHz
Frequency (MHz)	2410-2490	4920-5925	5925-7125
Return Loss (dB)	~-14.9	~-21.6	~-14.1
VSWR	~1.5:1	~1.2:1	~1.6:1
Efficiency (%)	~50.0	~49.7	~41.1
Peak Gain (dBi)	~-4.1	~-6.8	~-6.1
Average Gain (dB)	~-3.0	~-3.0	~-2.8
Impedance (Ohm)	50		
Polarisation	Linear		
Radiation Pattern	Omni-Directional		
Max. Input Power (W)	25		
Connector Type	SMA-Male-RP		
Cable Length	150 cm		
Cable Type	D302		

**Antenna Measurement Conditions:**

Mounted on Metal Plate of 30 x 30 cm

100 cm of Cable D302

Measured in Certified CTIA 3D Anechoic Chamber

## 2. Mechanical and environmental specifications

Specifications	OPT1-ANT-5GSDWG-15
Mounting Type	Screw Mount
Dimensions (mm)	199 × 167 × 53
Tighten Torque (Nm)	6 Nm
Radome Type	ASA
Radome color	Black, White
Operating Temperature (C)	-40 to +85
Storage Temperature (C)	-40 to +85
Substance Compliance	RoHS
Certificates	IP67, IP69

### 3. Antenna parameters

Cable 1: 5GNR

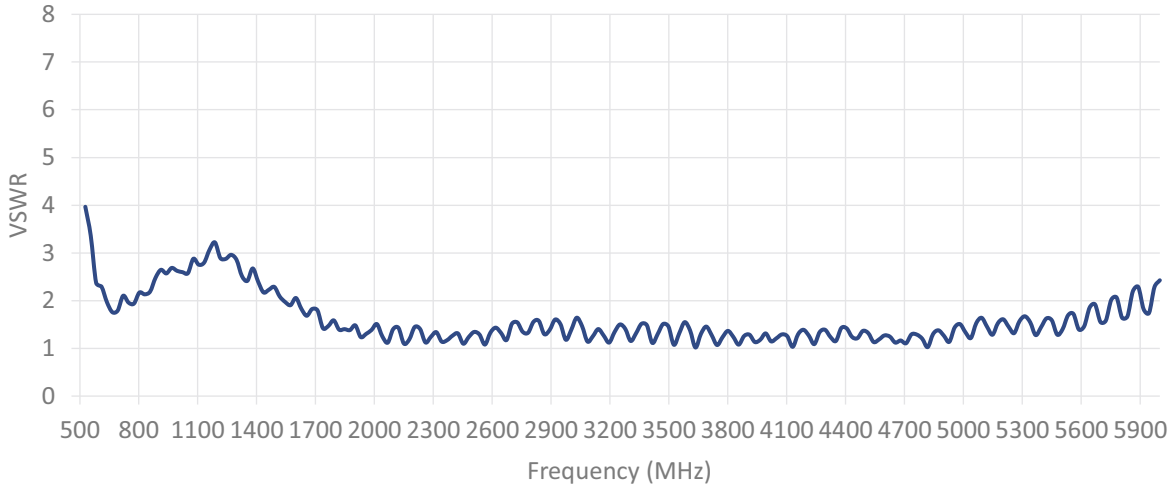
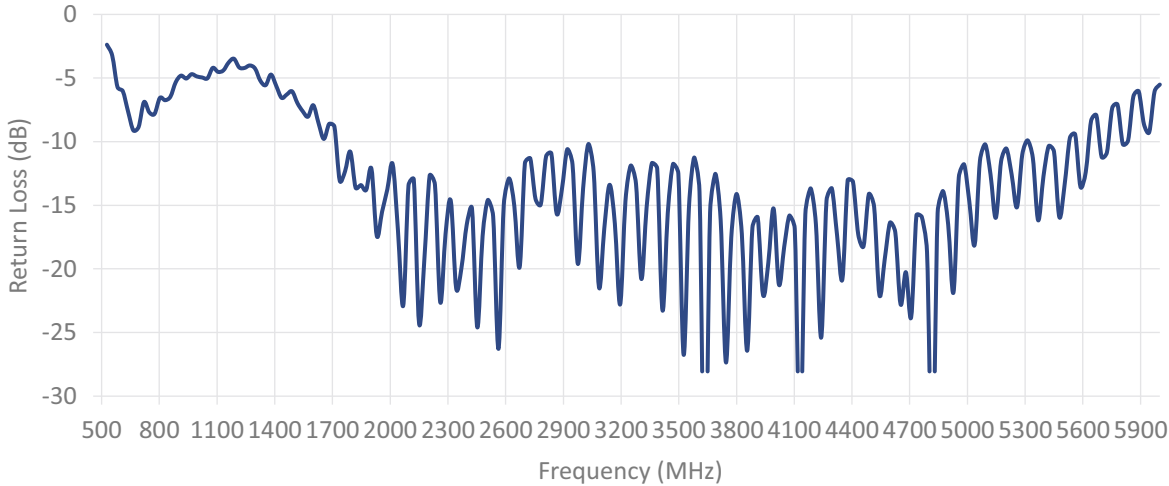

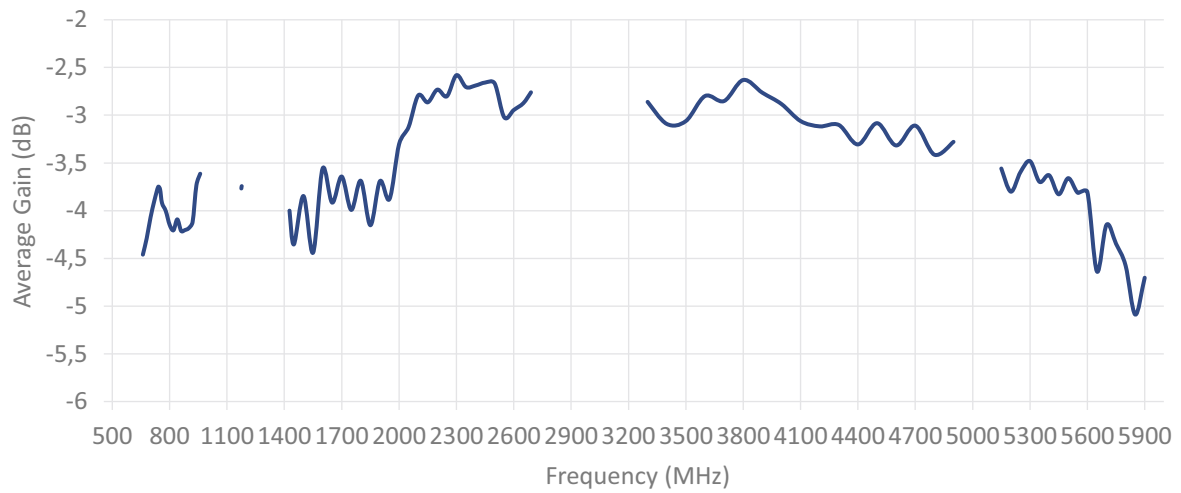
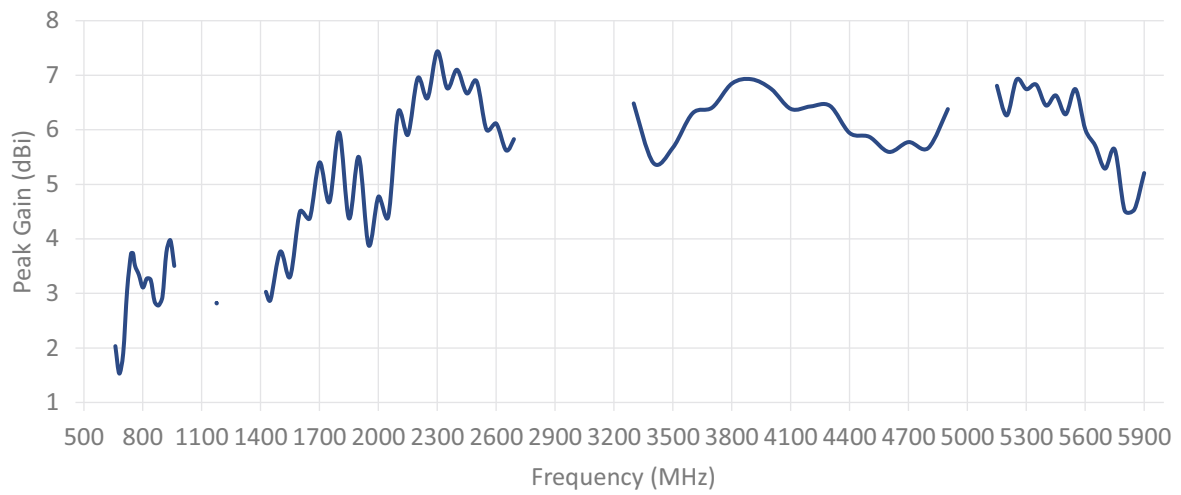
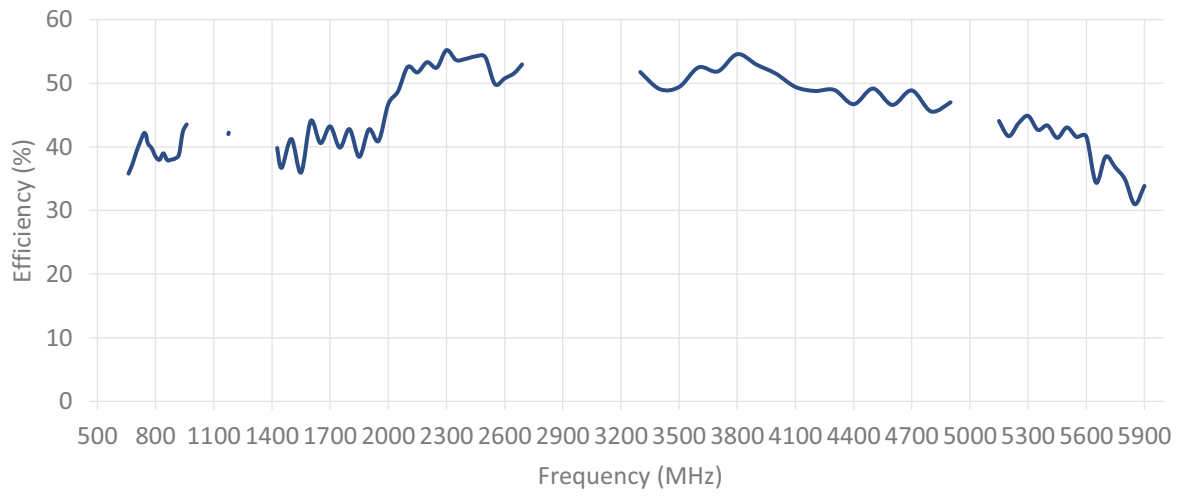

Cable 2: 5GNR

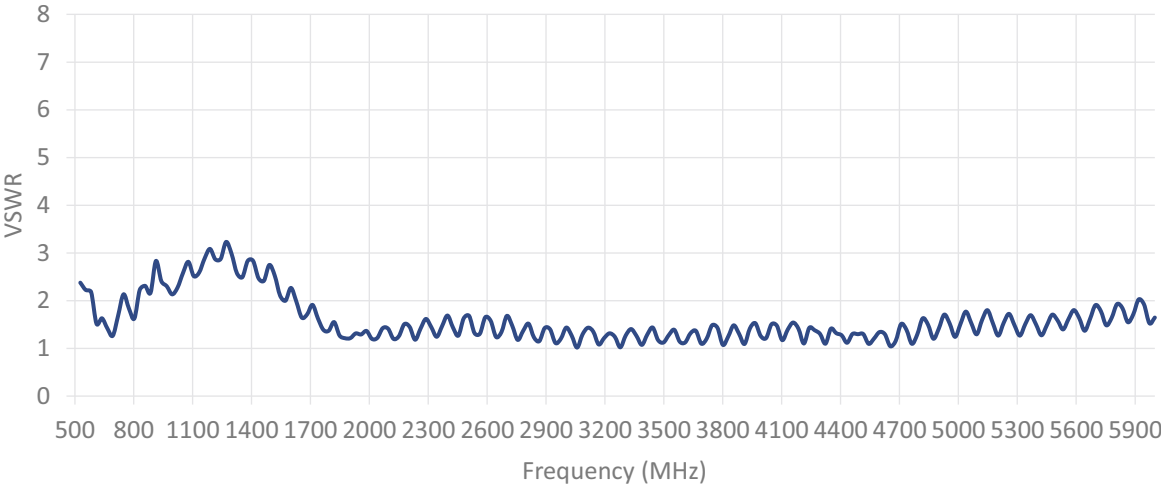
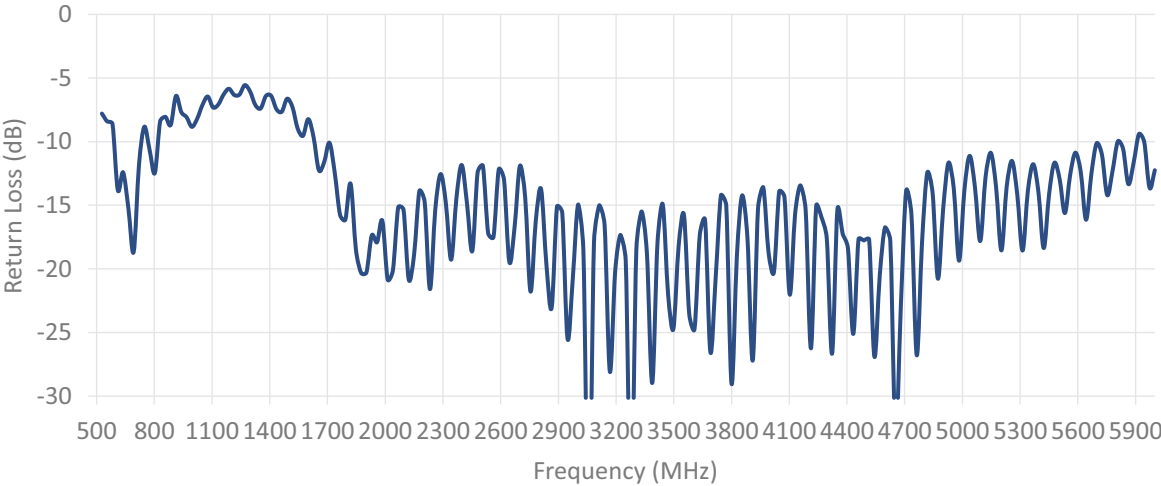

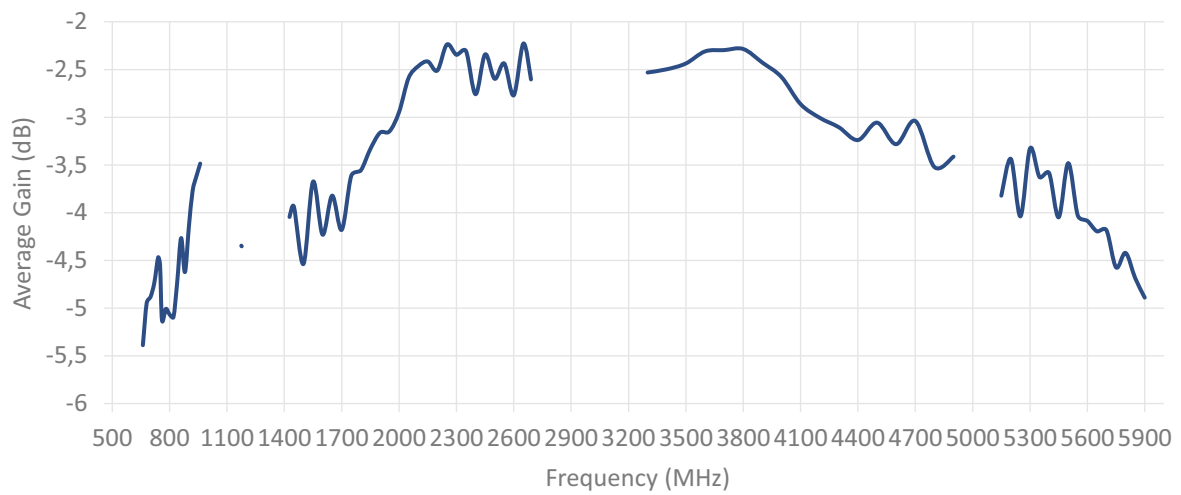
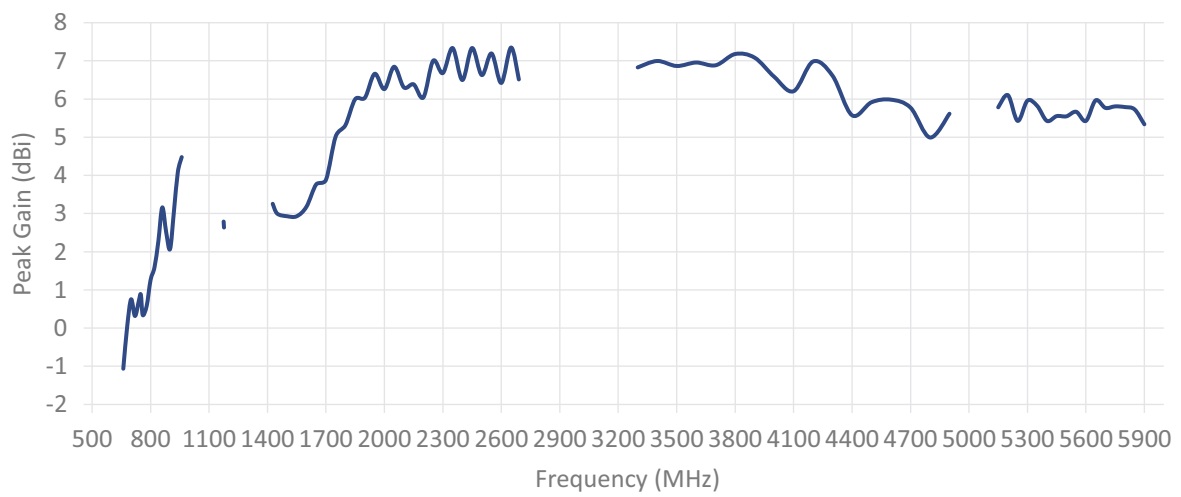
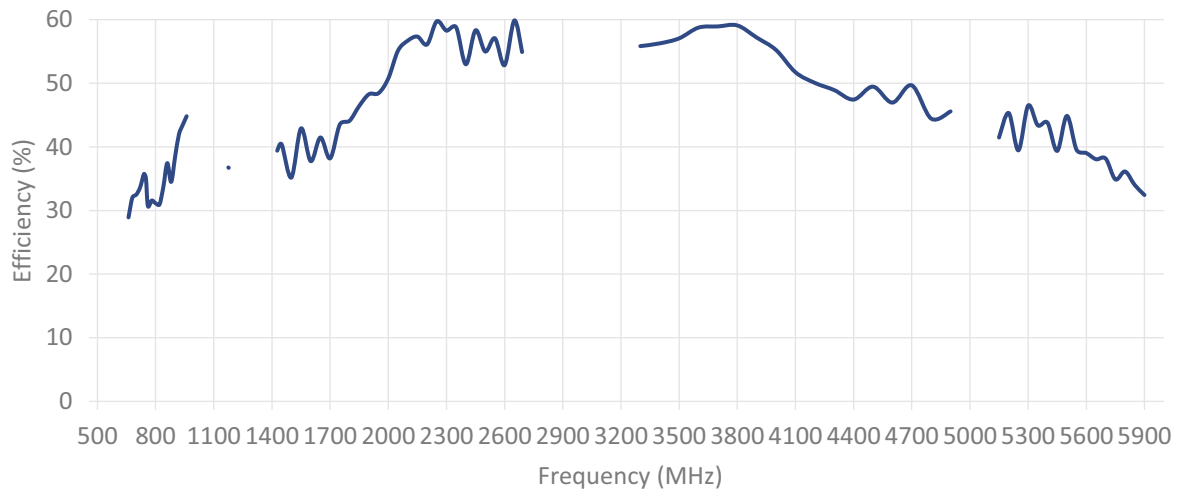

Cable 3: 5GNR

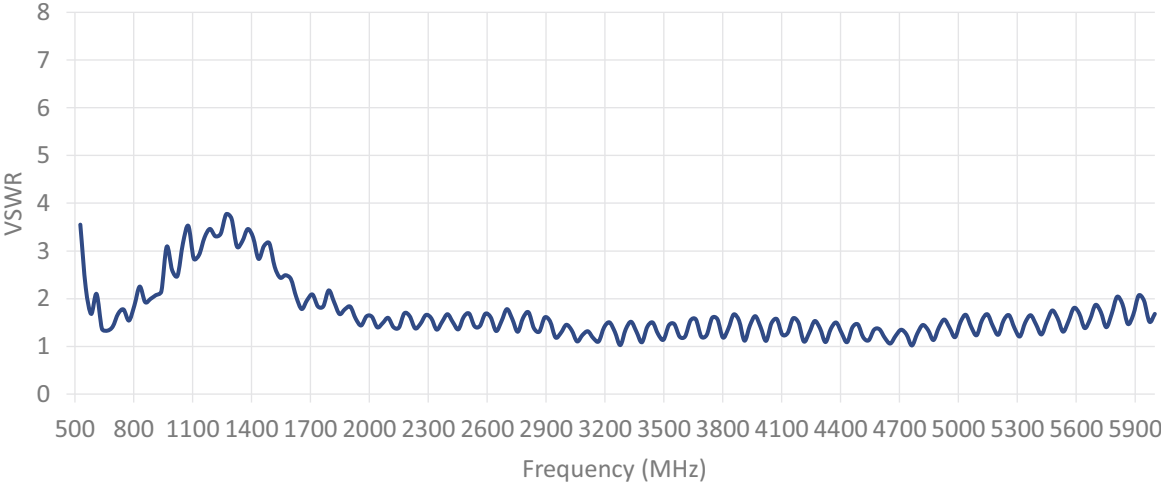
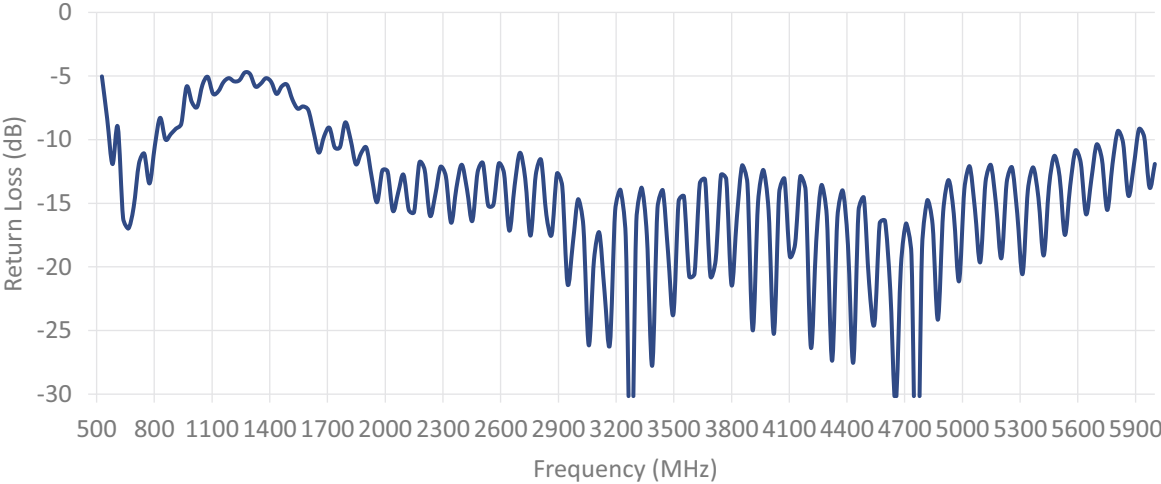

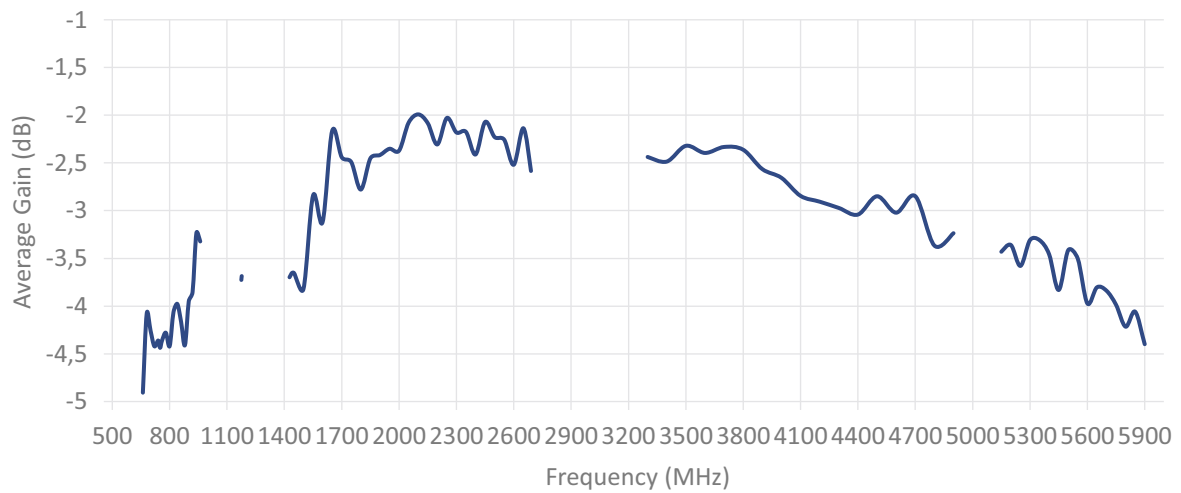
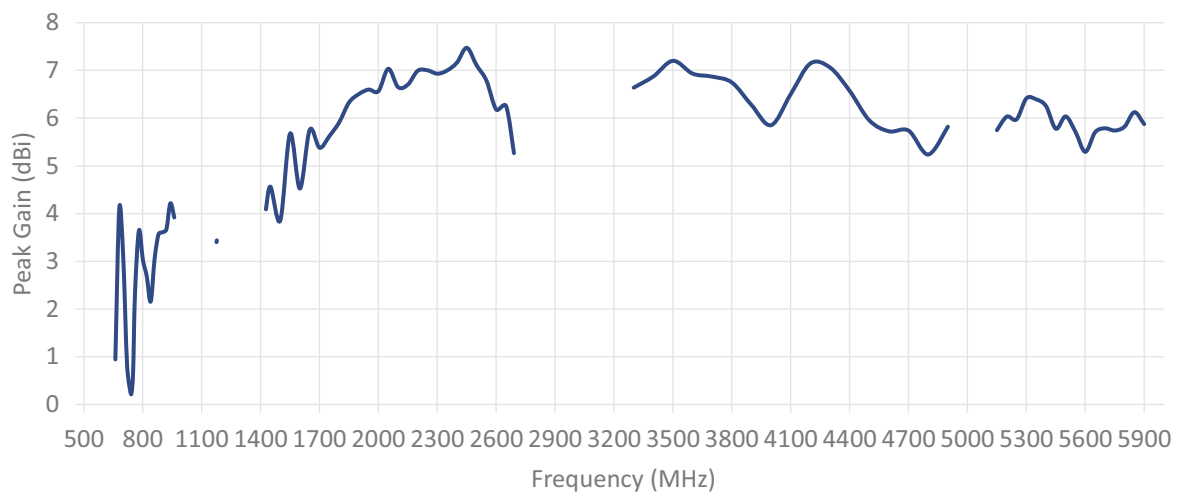
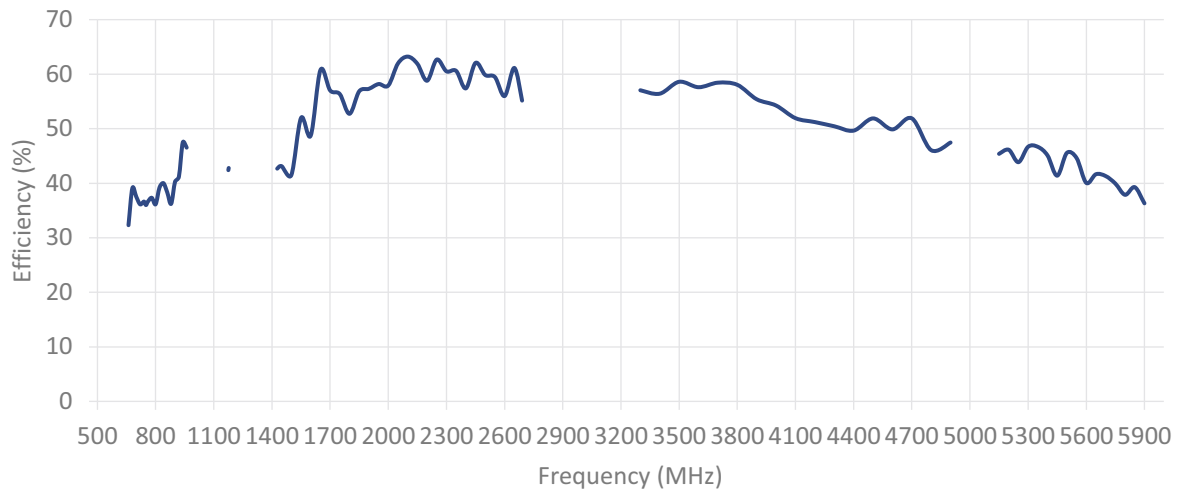

Cable 4: 5GNR

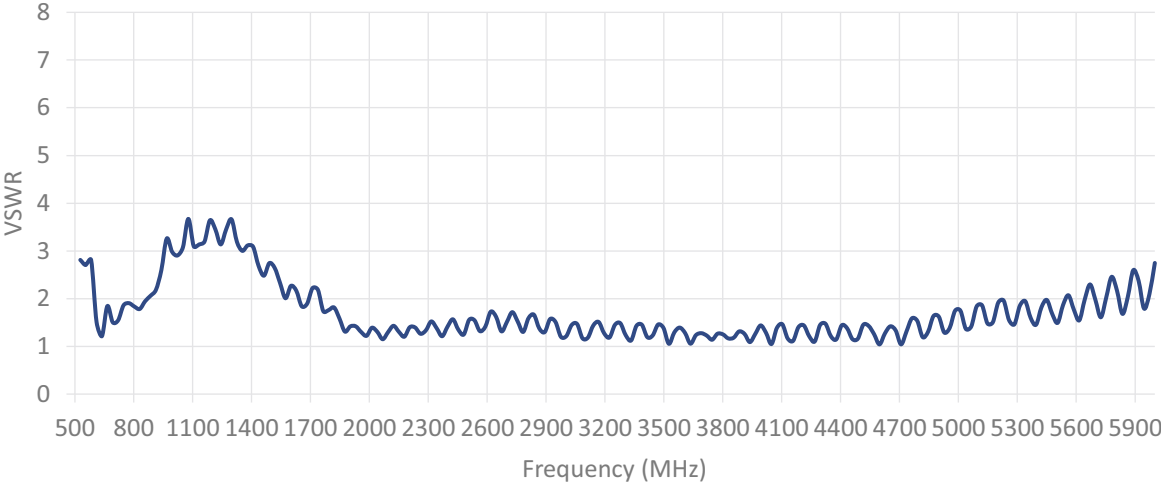
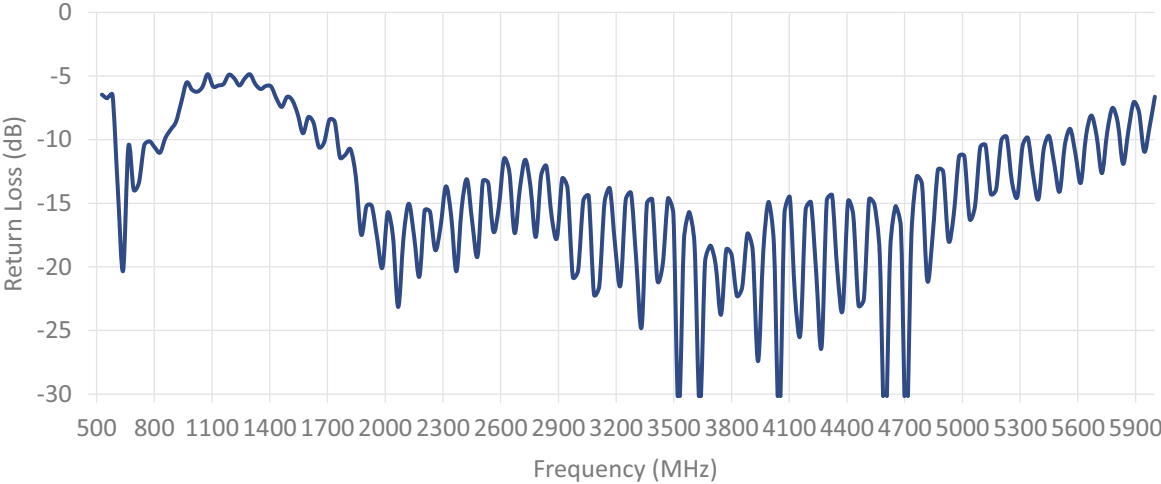

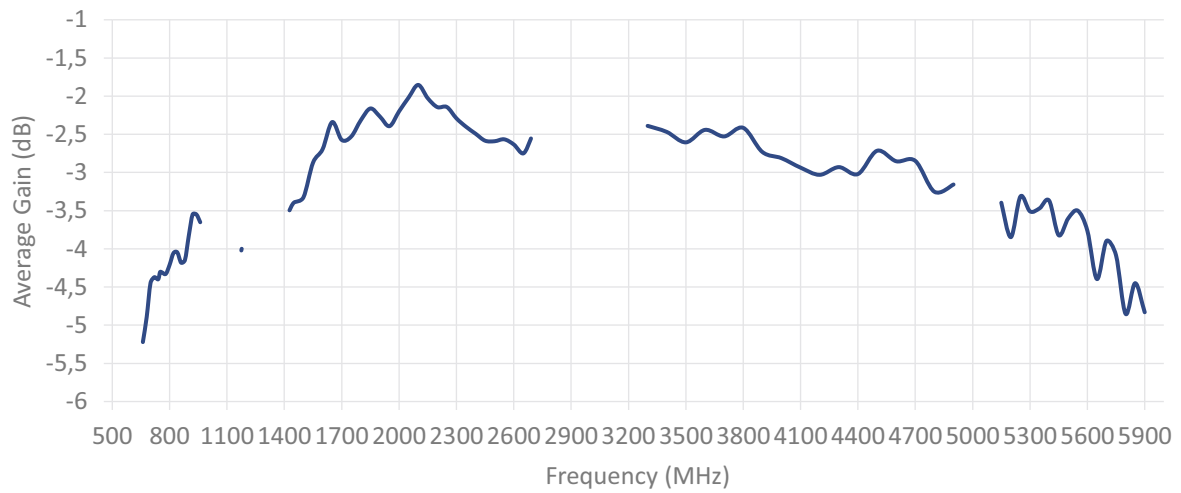
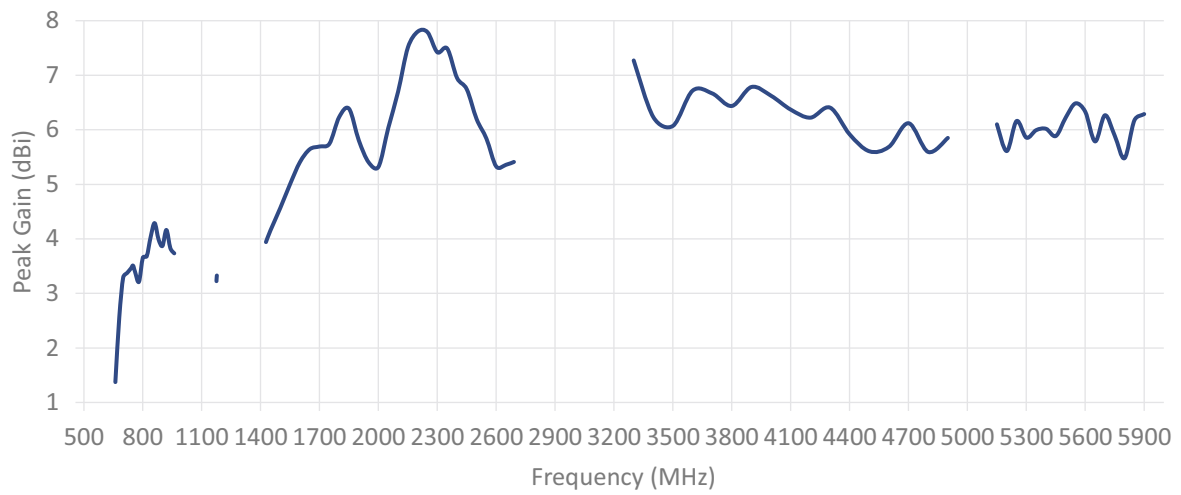
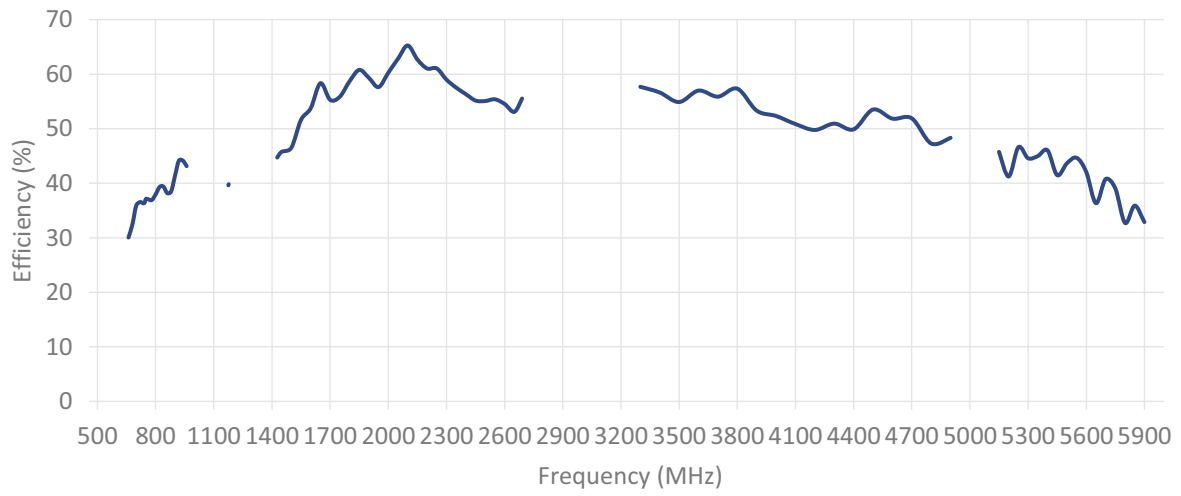

**ISOLATION FOR CABLES 1 AND 2**

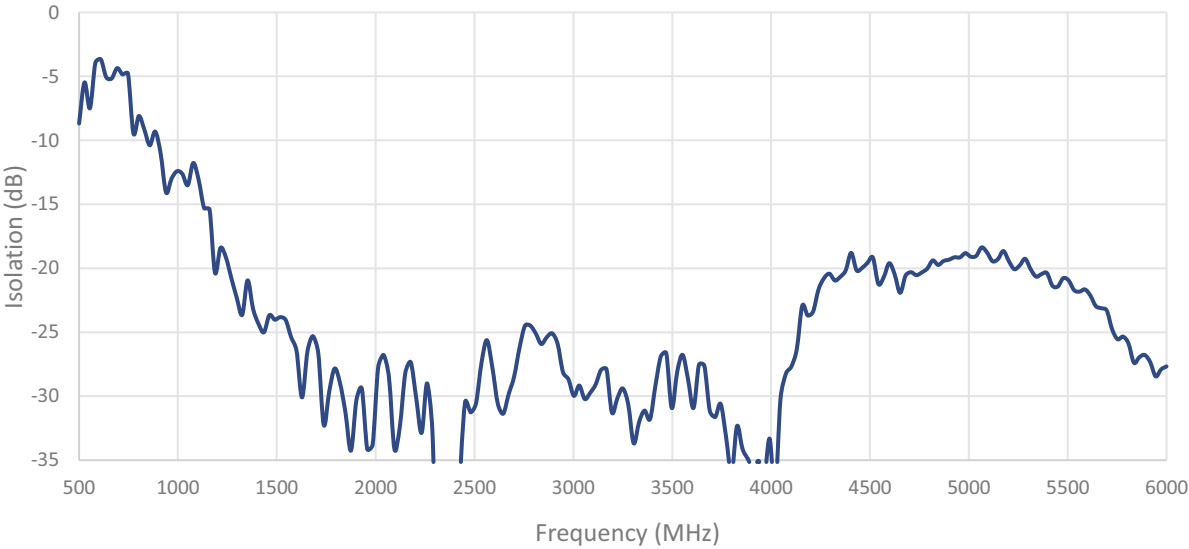

**ENVELOPE CORRELATION COEFFICIENT FOR CABLES 1 AND 2**

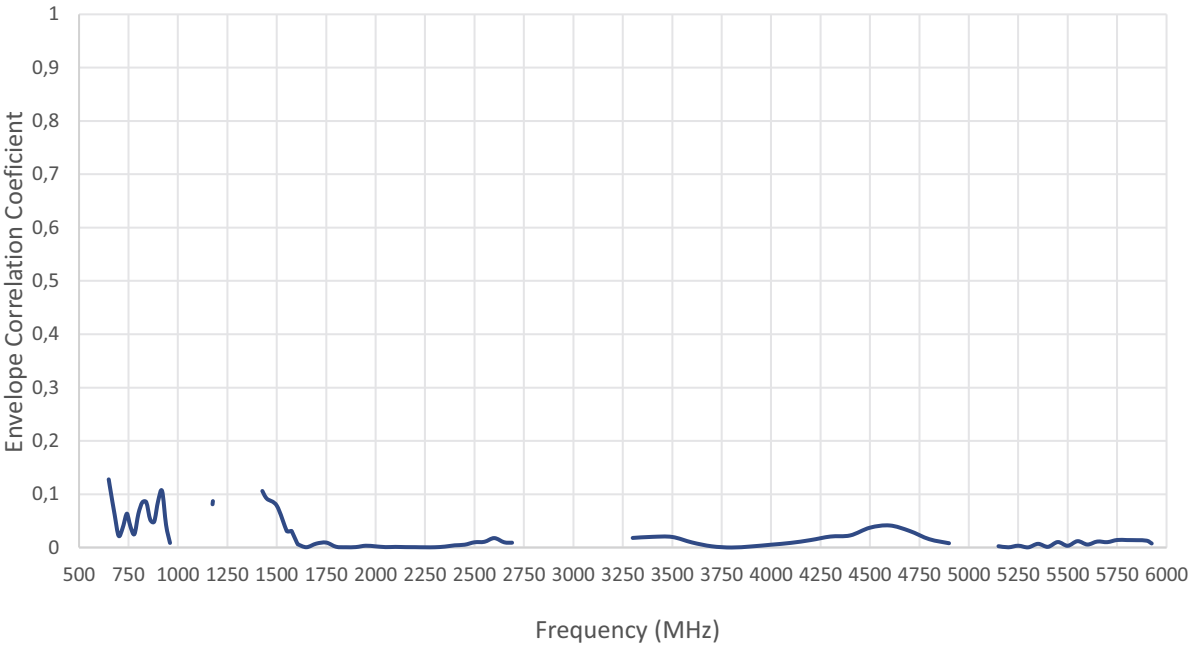

**ISOLATION FOR CABLES 1 AND 3**

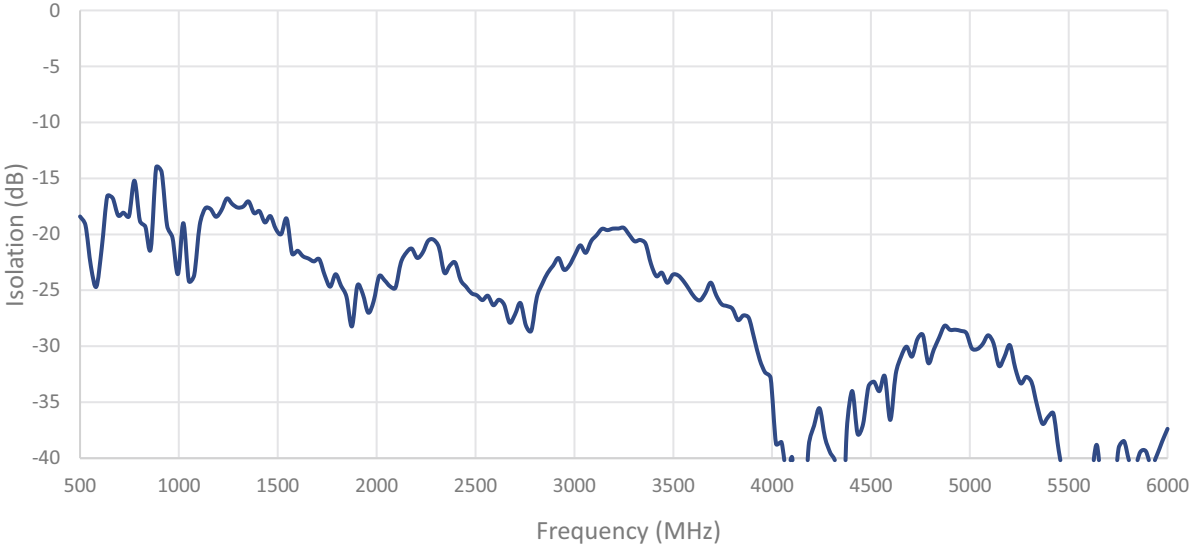

**ENVELOPE CORRELATION COEFFICIENT FOR CABLES 1 AND 3**

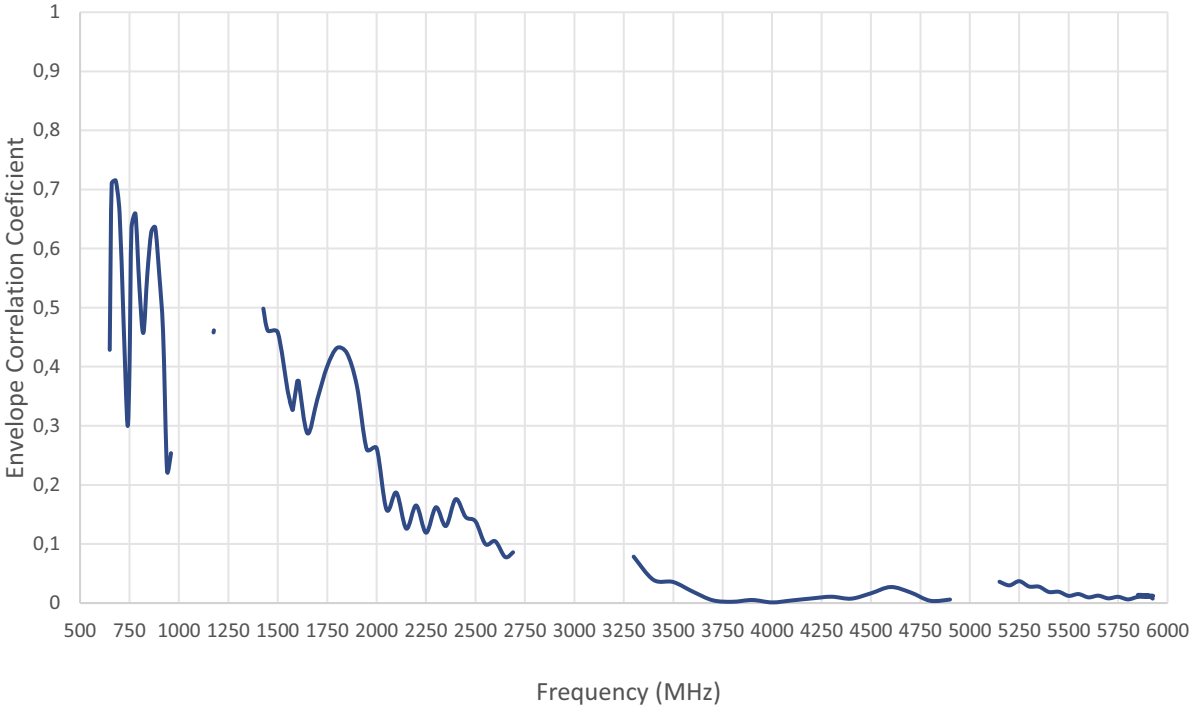

**ISOLATION FOR CABLES 1 AND 4**

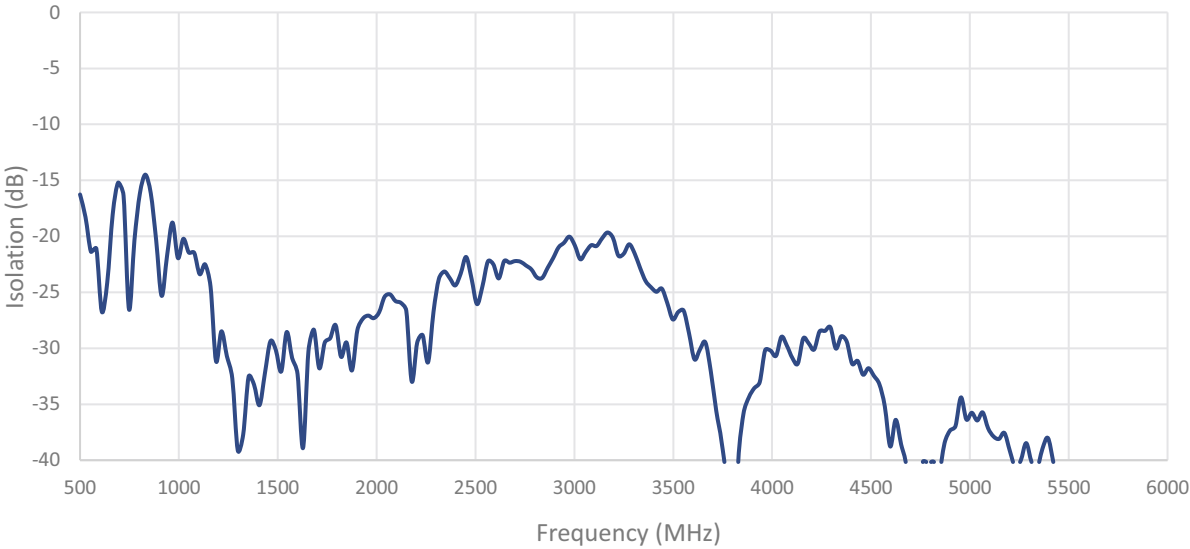

**ENVELOPE CORRELATION COEFFICIENT FOR CABLES 1 AND 4**

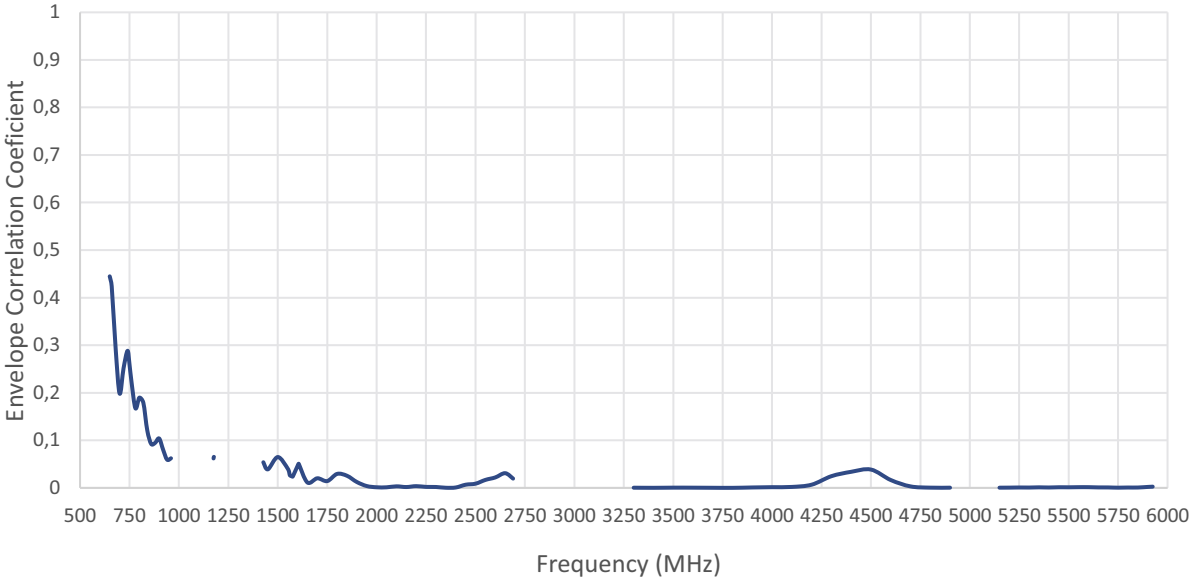

**ISOLATION FOR CABLES 2 AND 3**

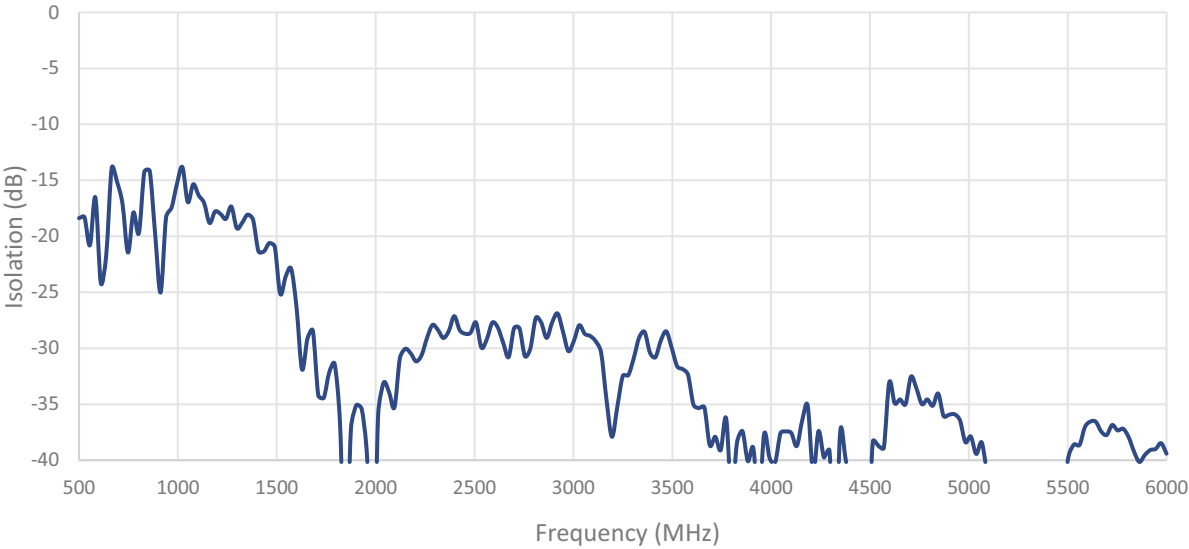

**ENVELOPE CORRELATION COEFFICIENT FOR CABLES 2 AND 3**

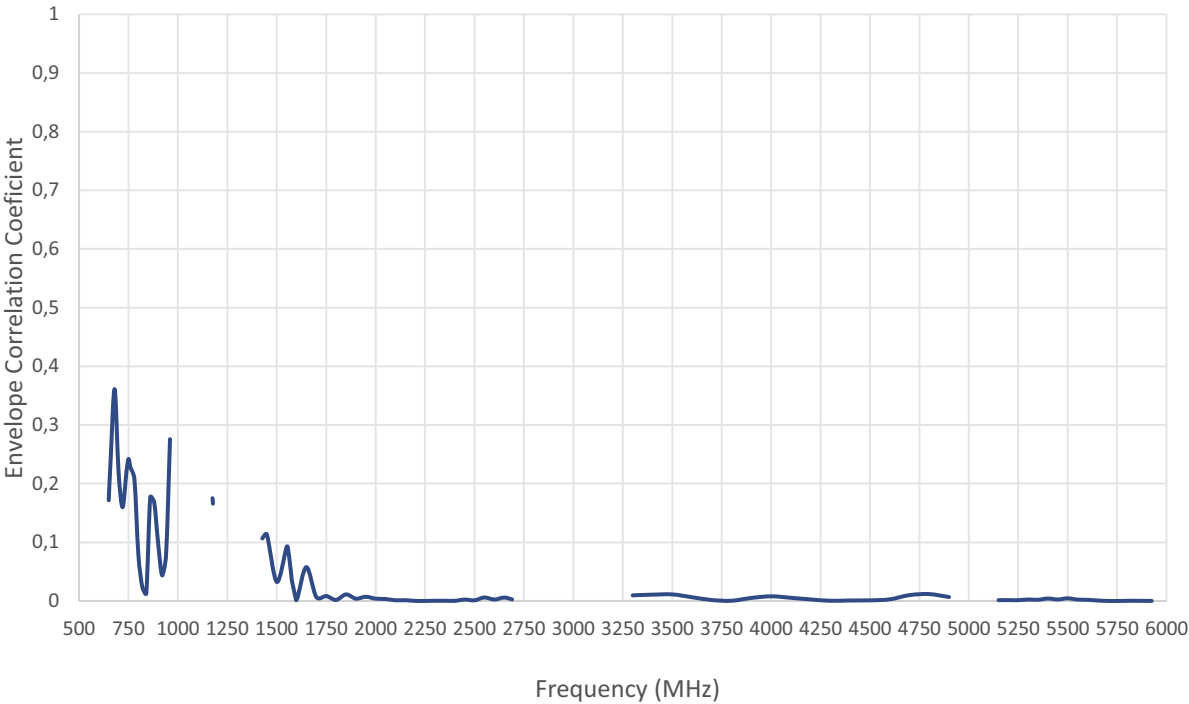

Cable 5: 2.4/5.0/6.0 GHz ISM

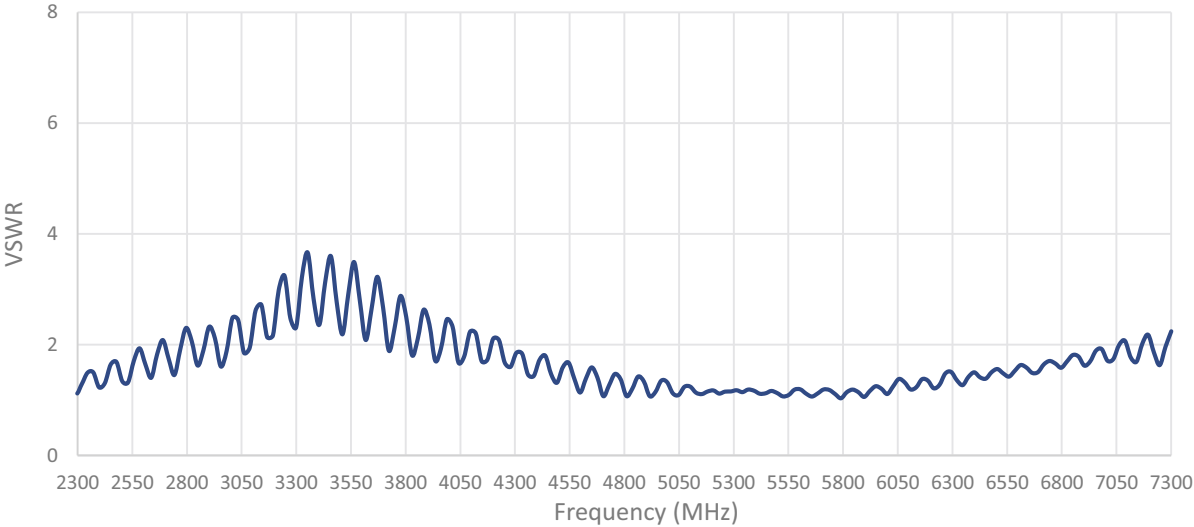
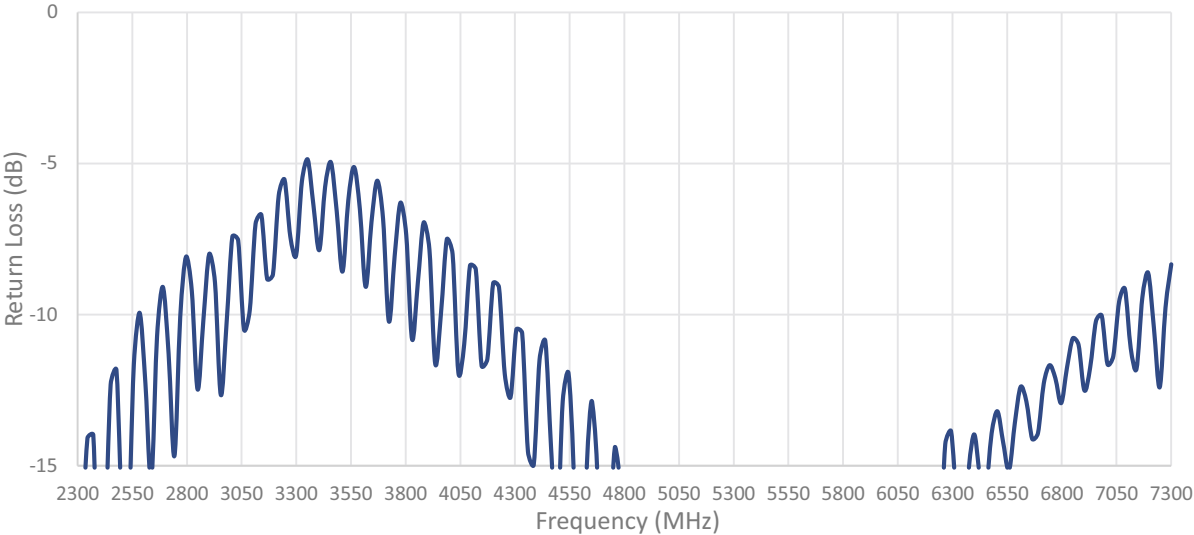

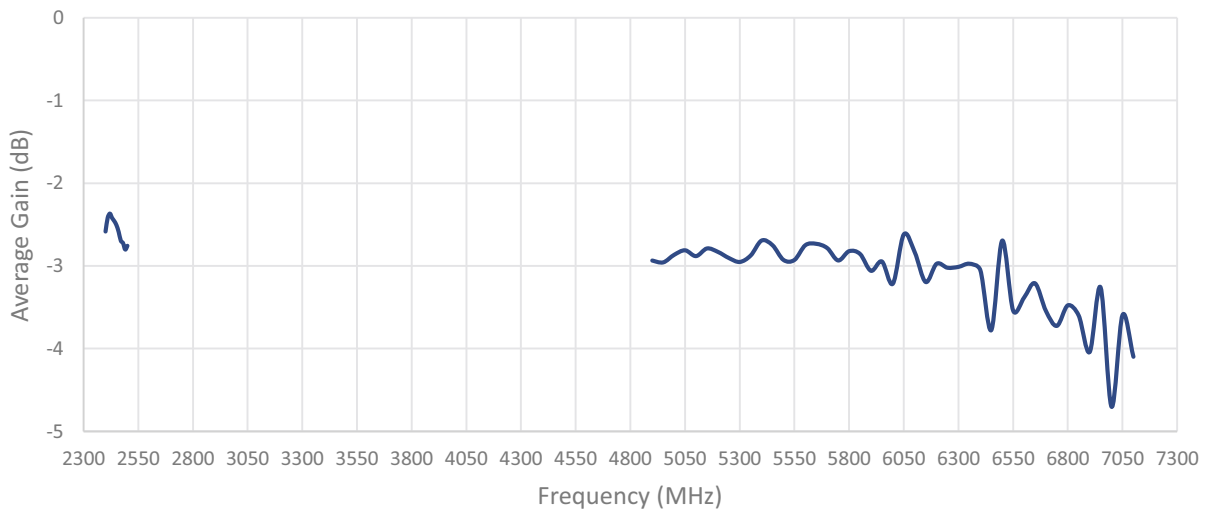
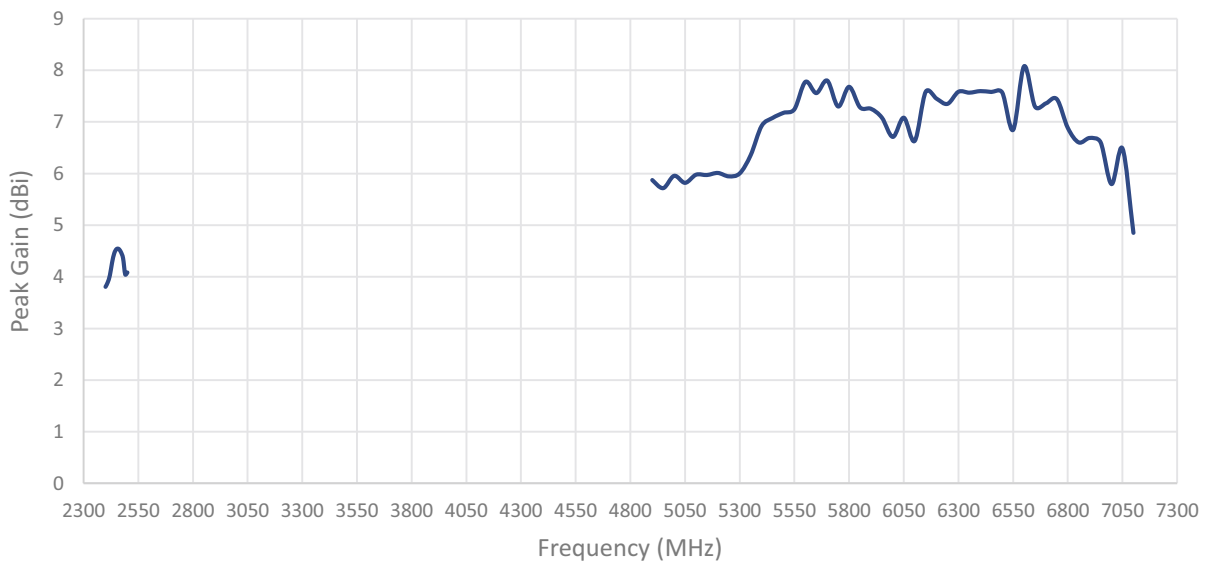
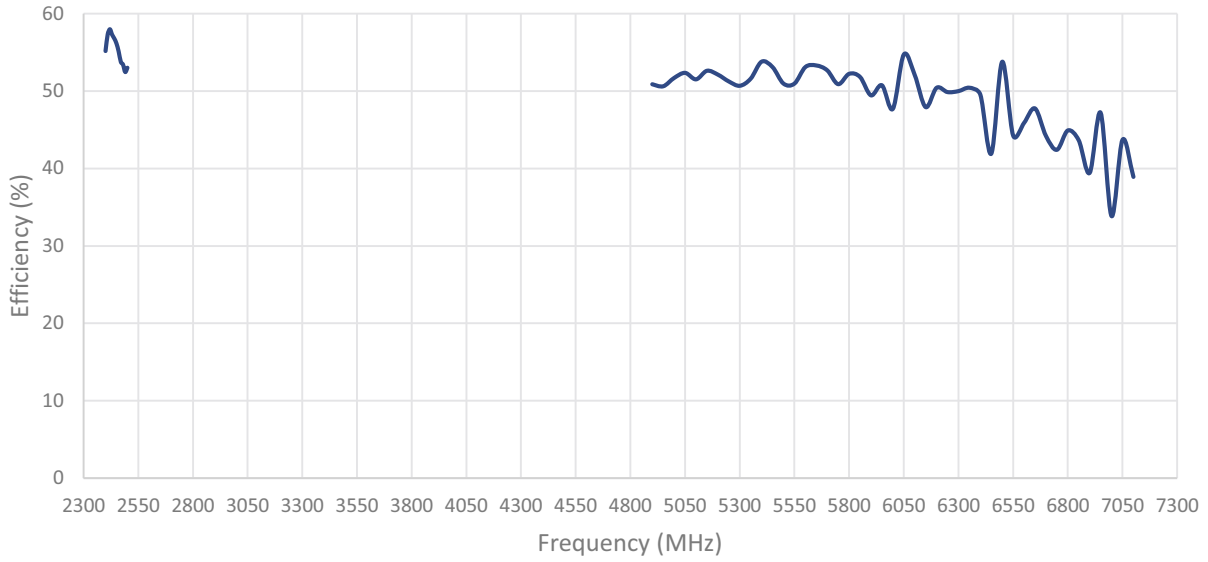

Cable 6: 2.4/5.0/6.0 GHz ISM

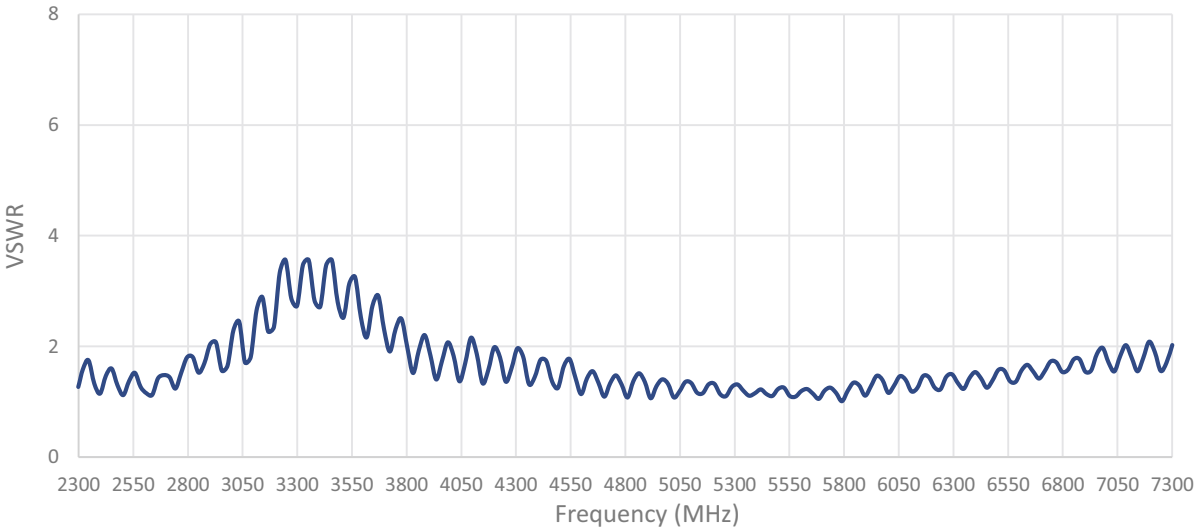
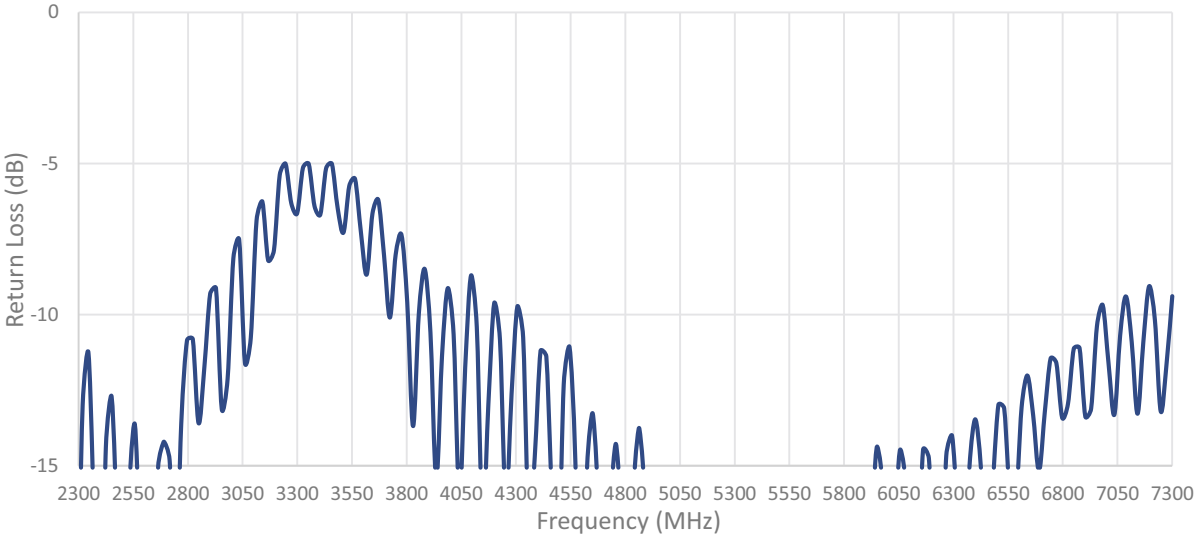

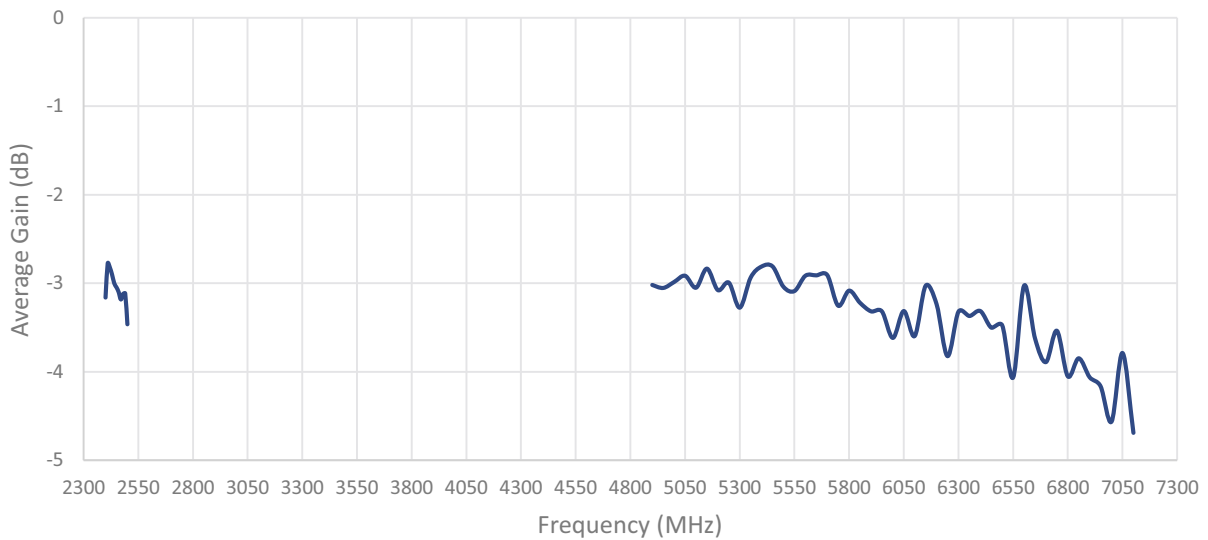
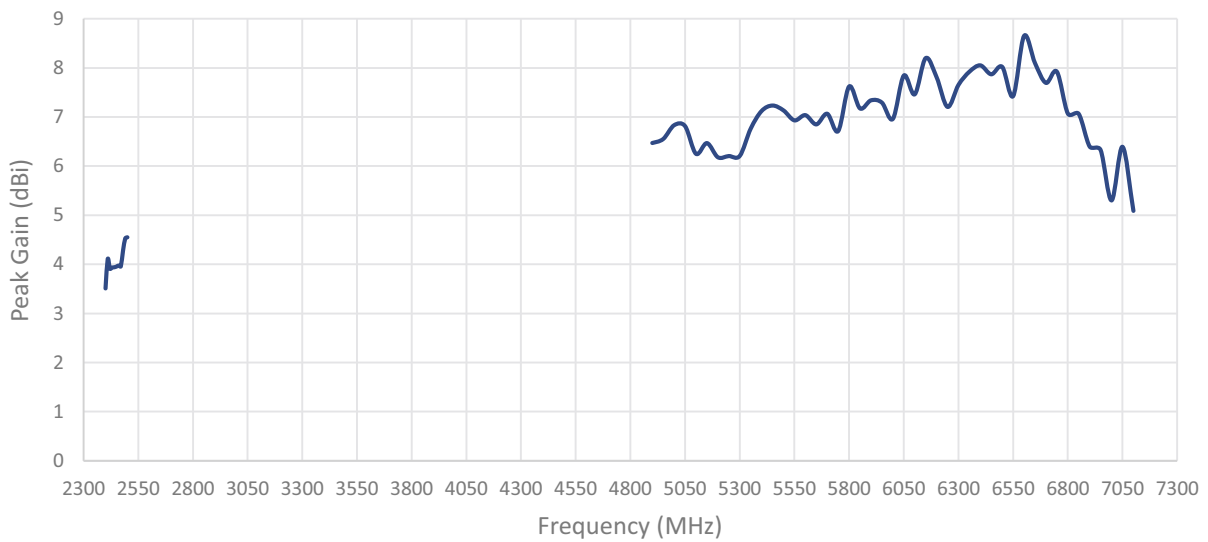
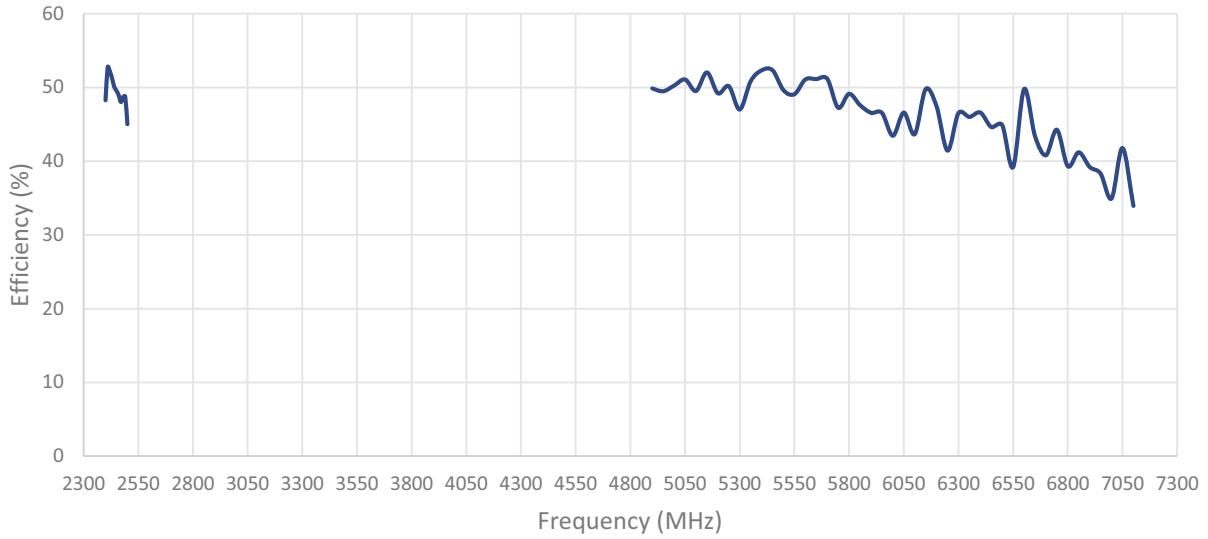

**ISOLATION FOR CABLES 5 AND 6**

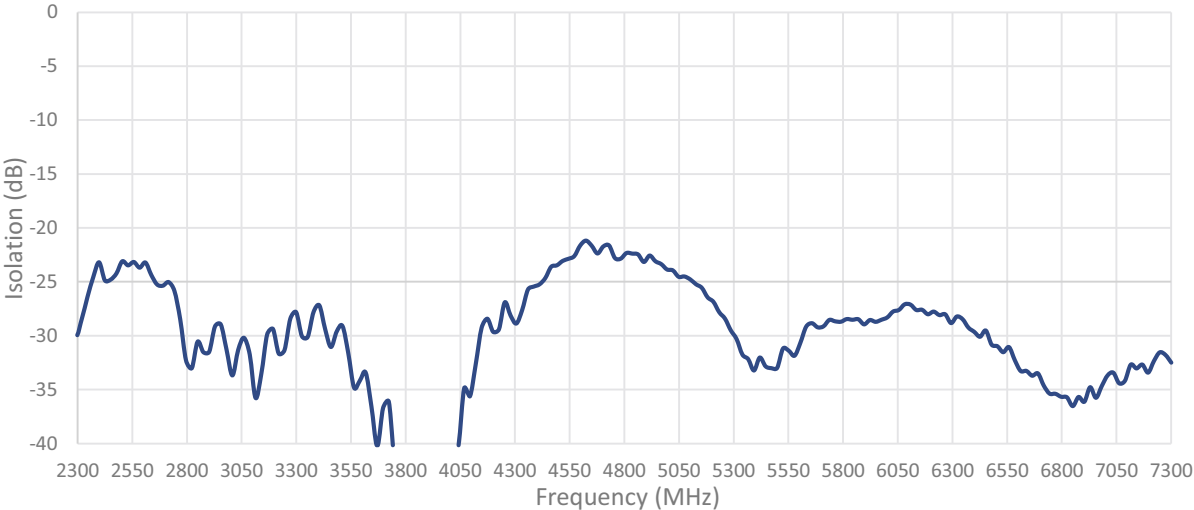

**ENVELOPE CORRELATION COEFFICIENT FOR CABLES 5 AND 6**

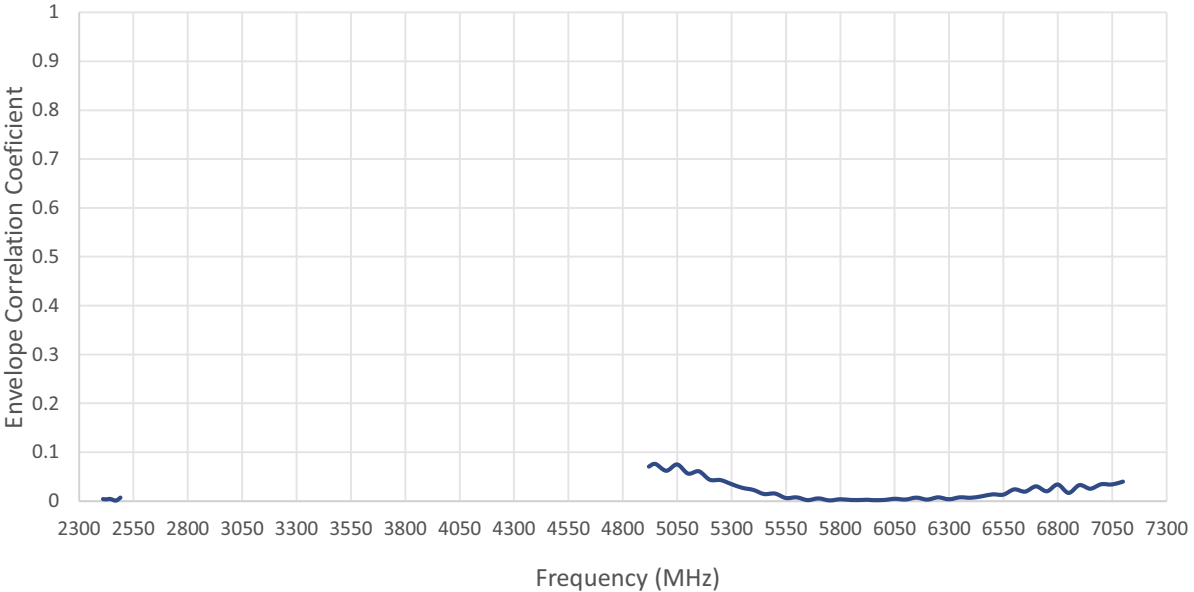

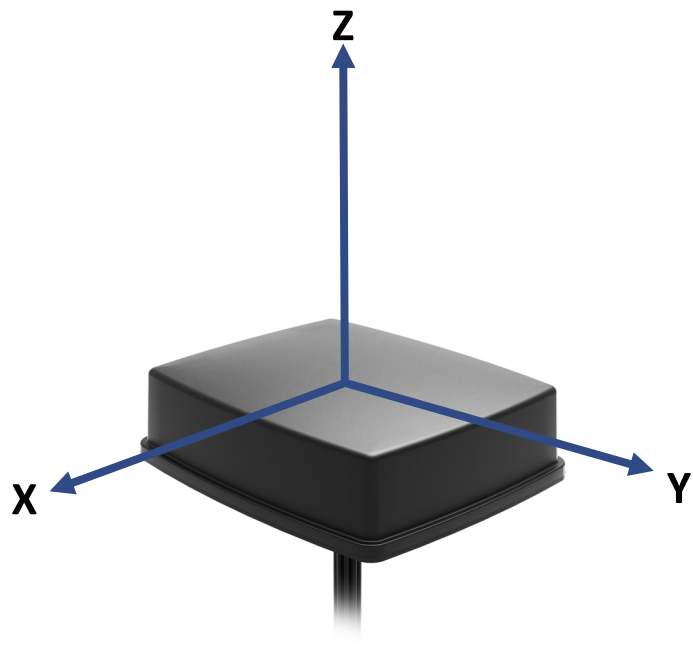

Radiation pattern reference

Cable 1: 5GNR

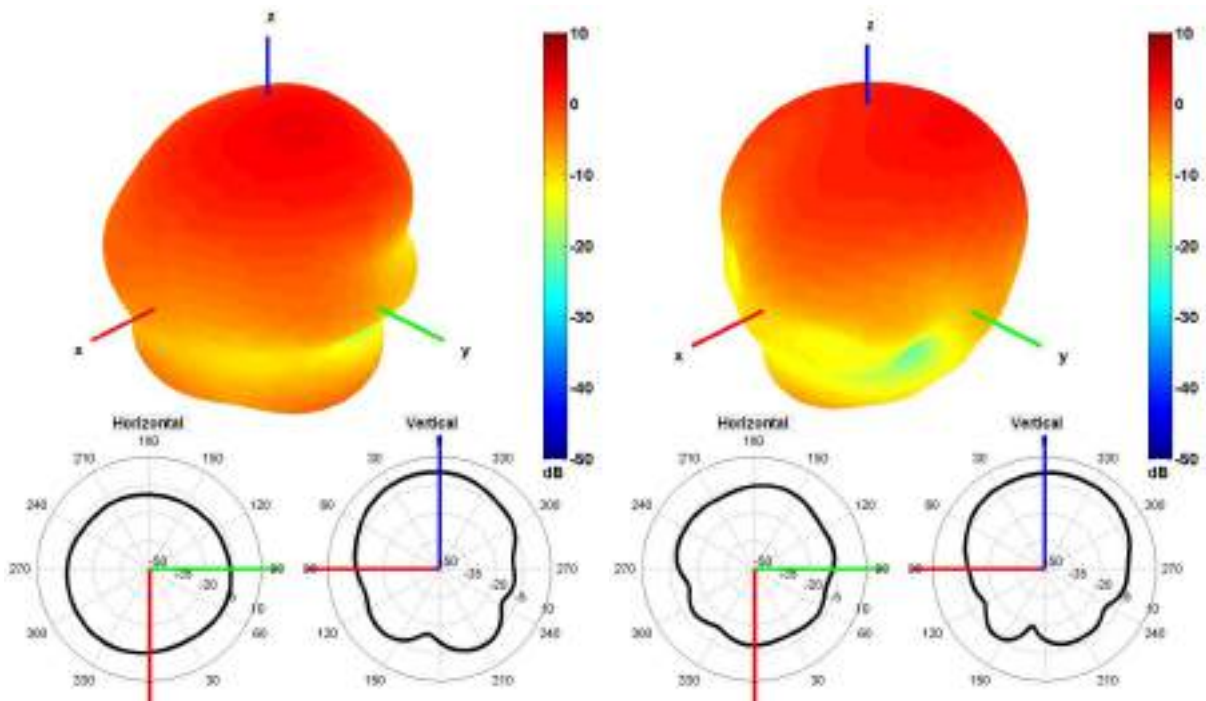

750 and 1176 MHz Radiation pattern

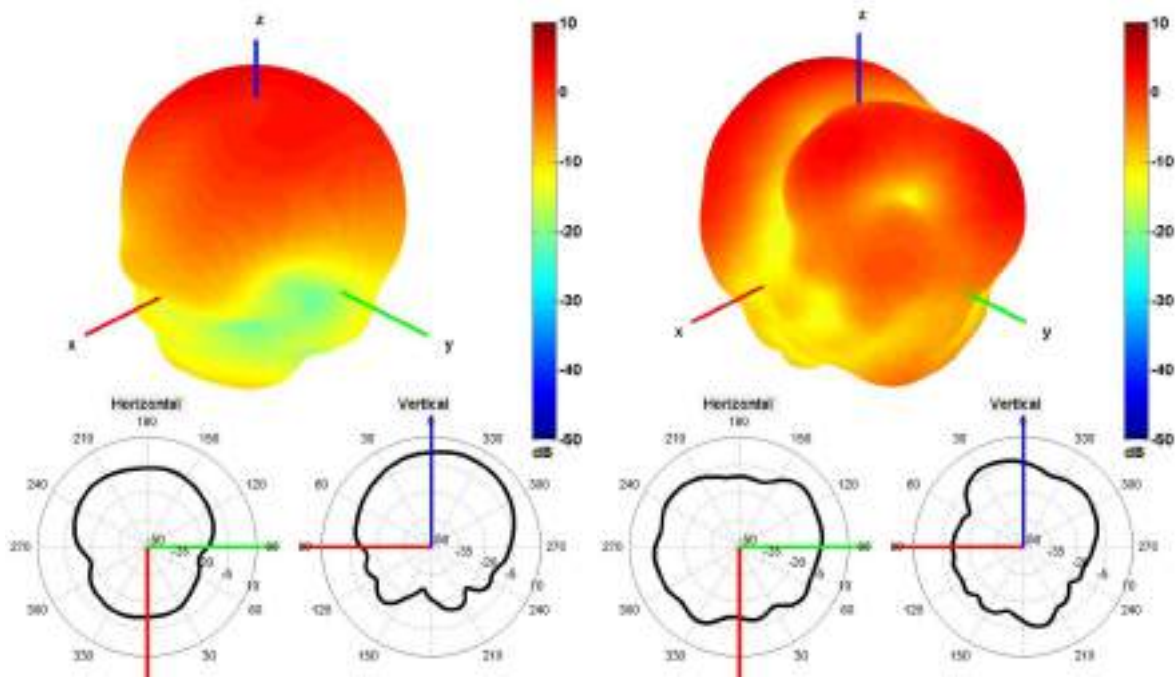

1575 and 2500 MHz Radiation pattern

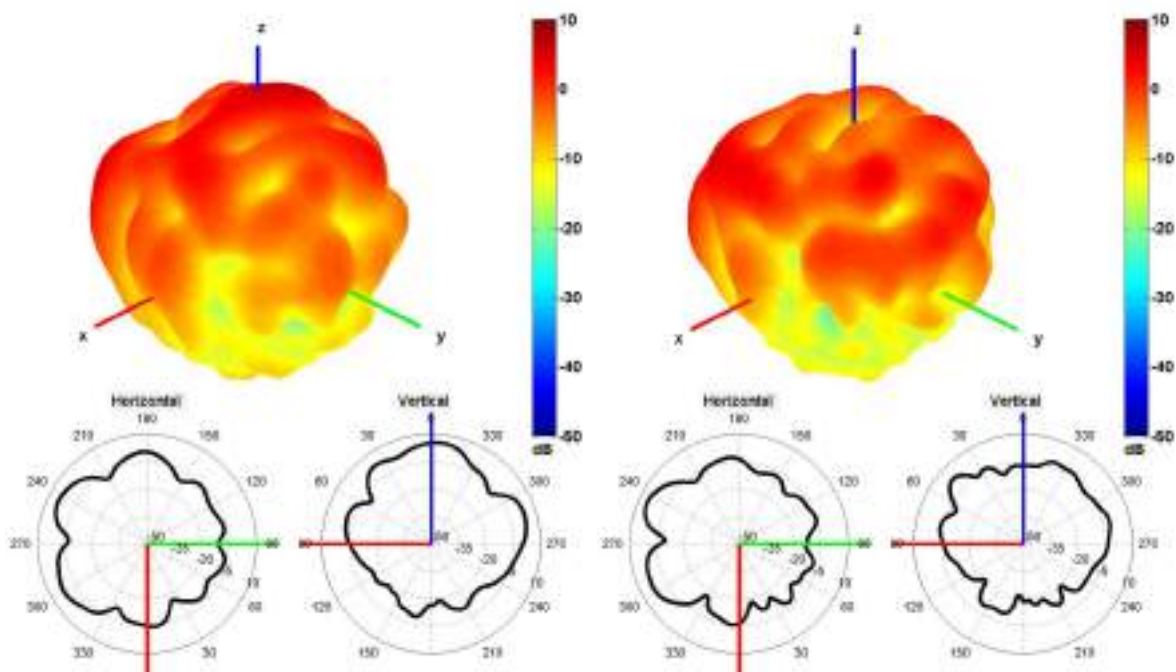

4500 and 5500 MHz Radiation pattern

Cable 2: 5GNR

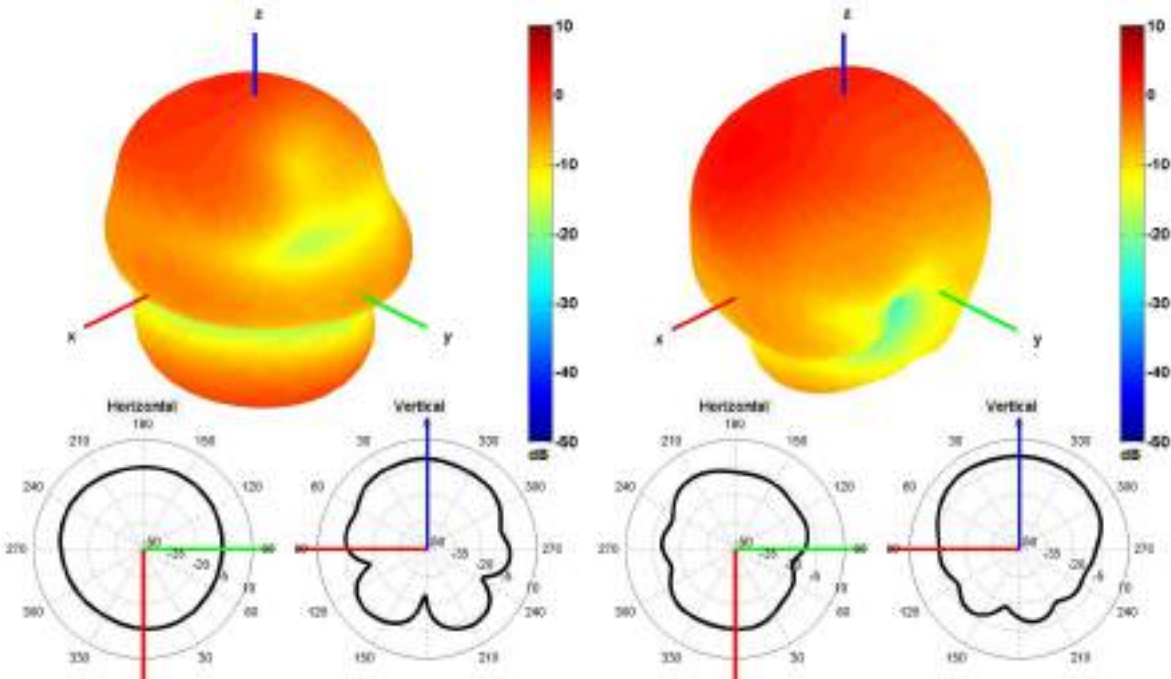

750 and 1176 MHz Radiation pattern

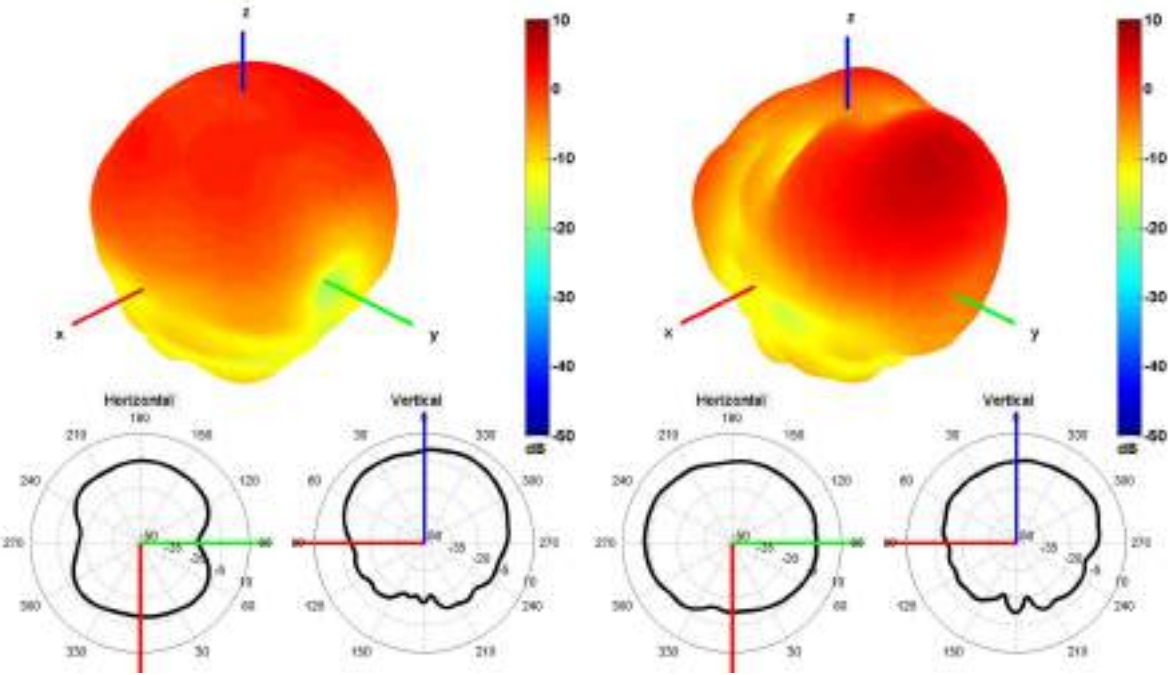

1575 and 2500 MHz Radiation pattern

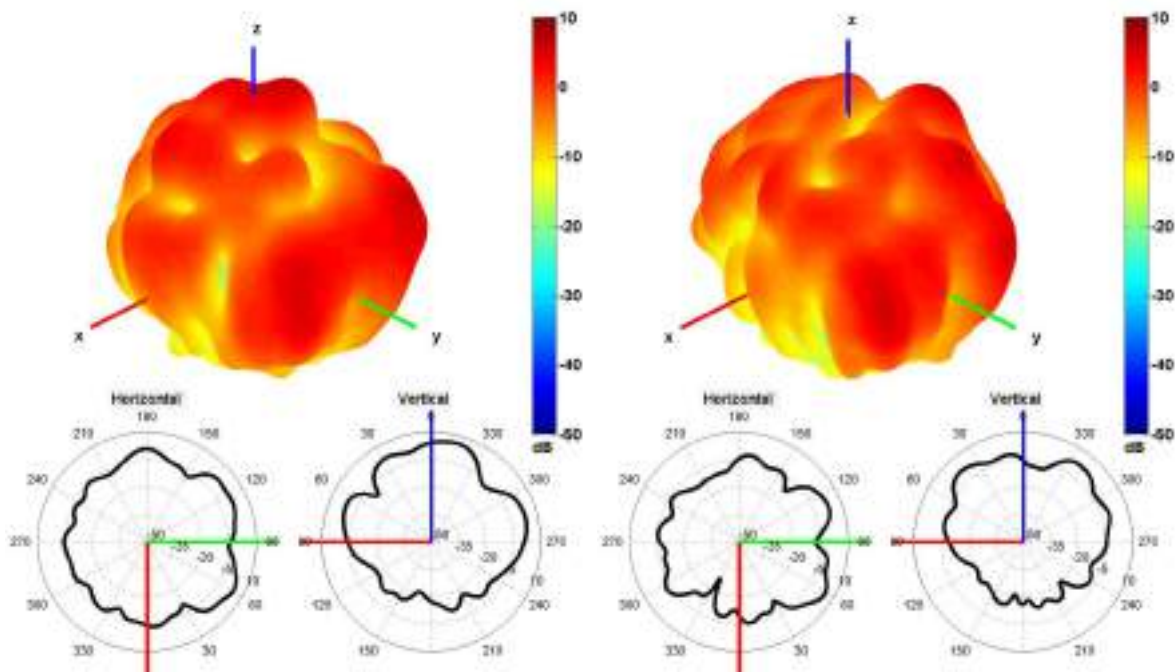

4500 and 5500 MHz Radiation pattern

Cable 3: 5GNR

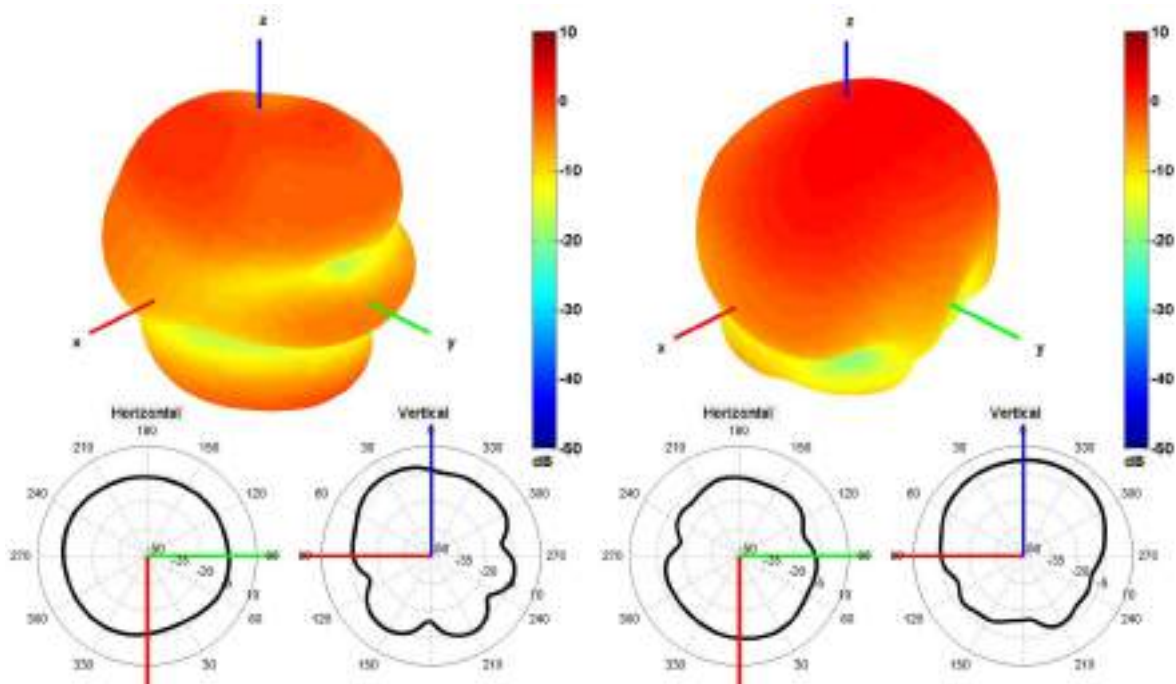

750 and 1176 MHz Radiation pattern

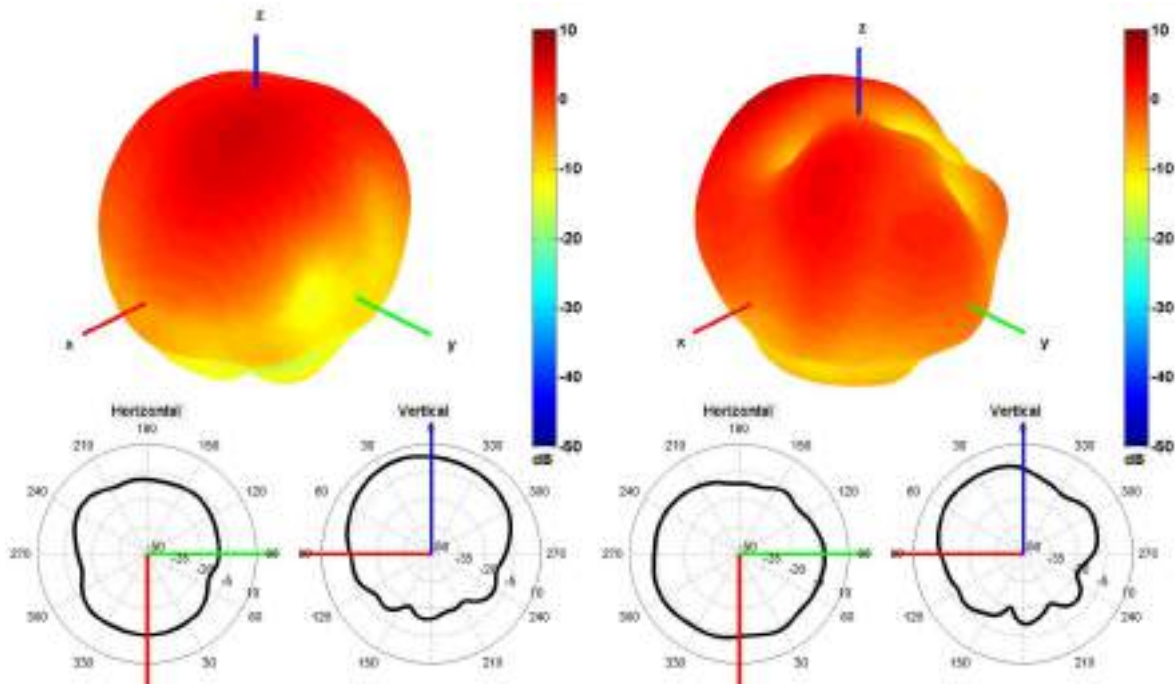

1575 and 2500 MHz Radiation pattern

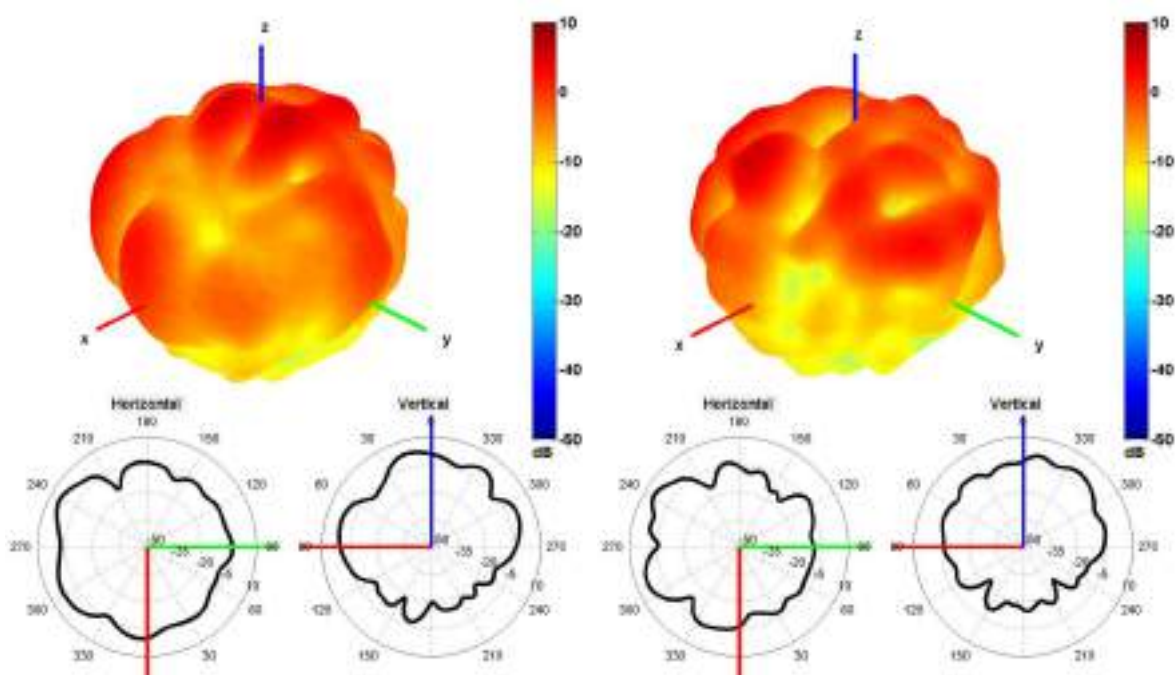

4500 and 5500 MHz Radiation pattern

Cable 4: 5GNR

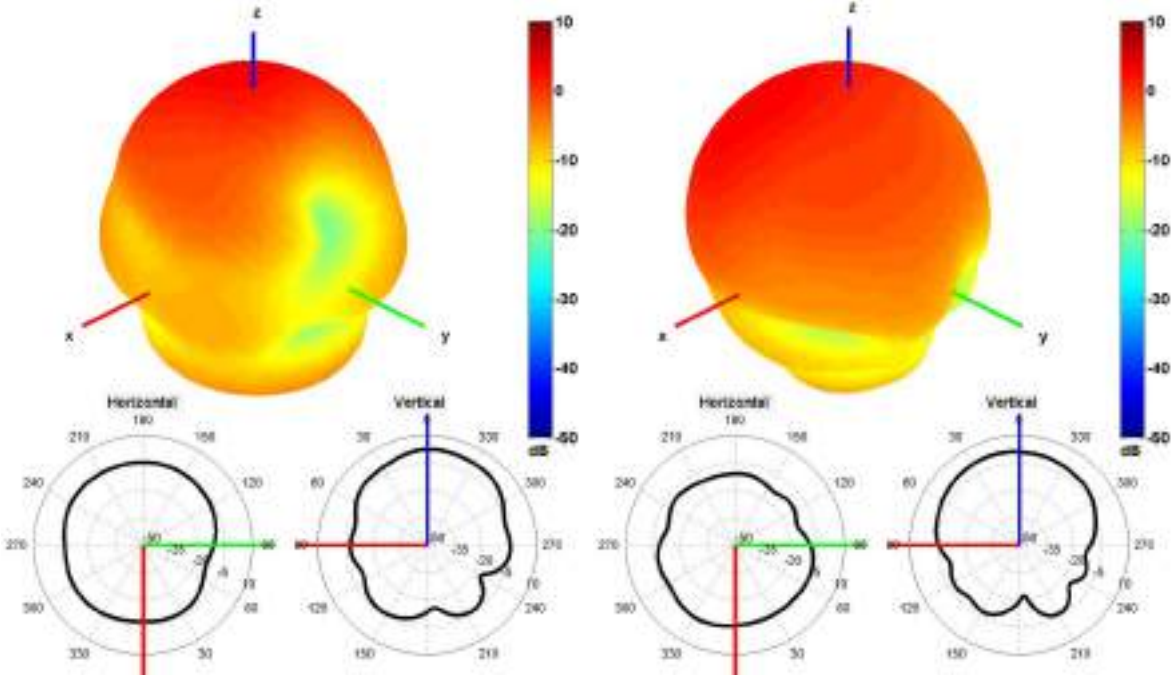

750 and 1176 MHz Radiation pattern

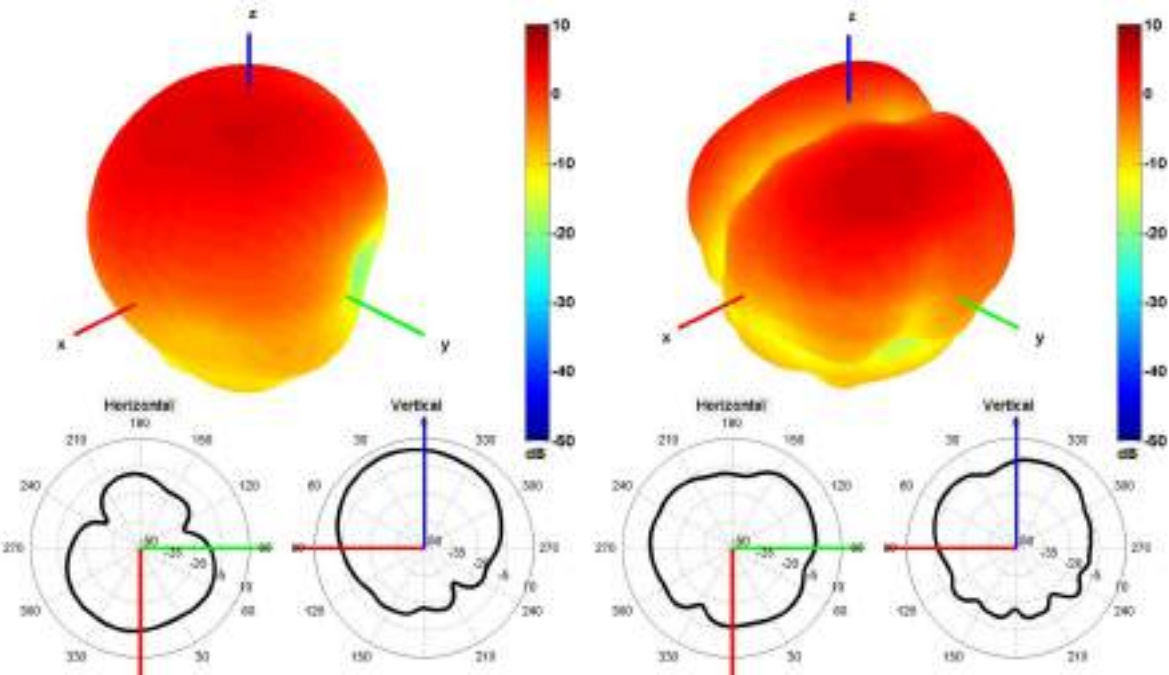

1575 and 2500 MHz Radiation pattern

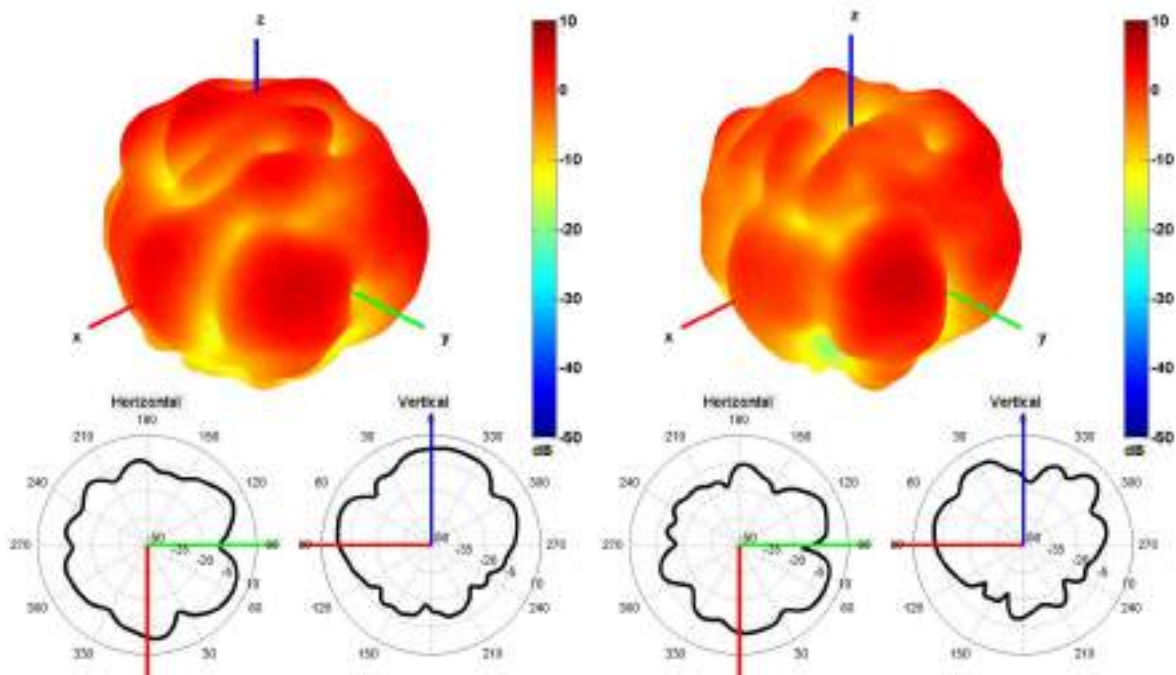

4500 and 5500 MHz Radiation pattern

Cable 5: 2.4/5.0/6.0 GHz ISM

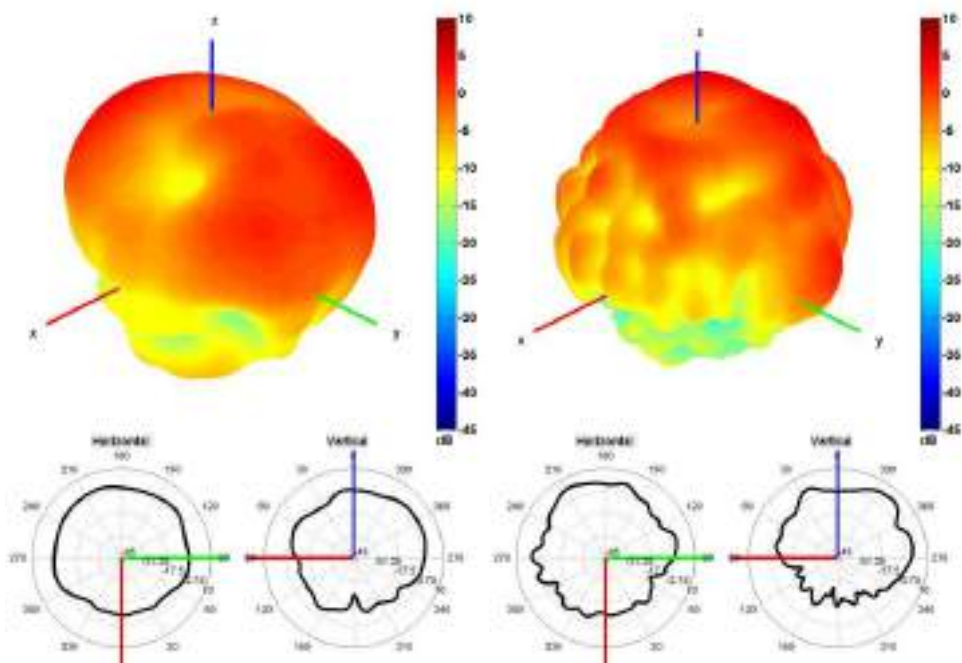

2450 and 5500 MHz Radiation pattern

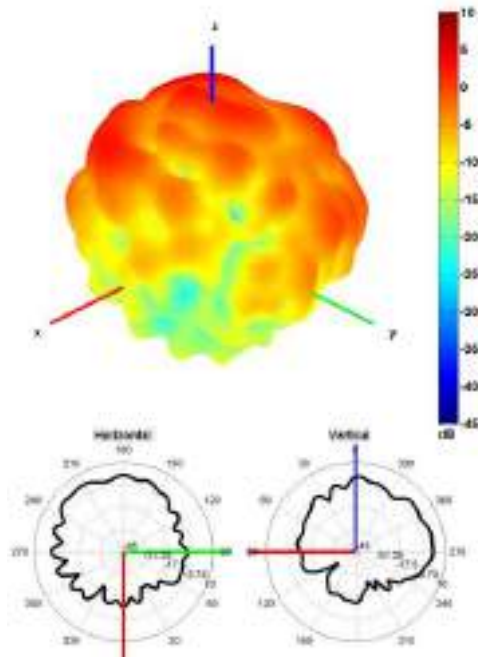

6500 MHz Radiation pattern

Cable 6: 2.4/5.0/6.0 GHz ISM

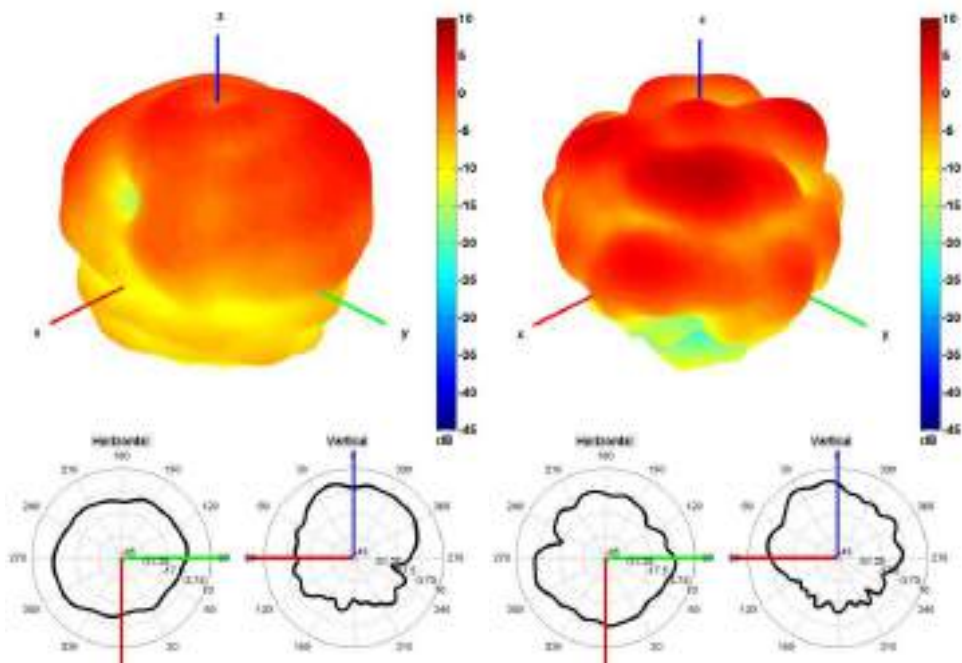

2450 and 5500 MHz Radiation pattern

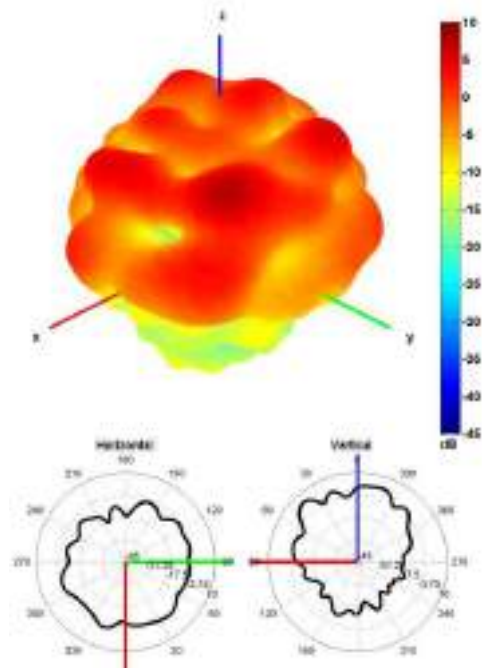

6500 MHz Radiation pattern

**4. Antenna drawings**

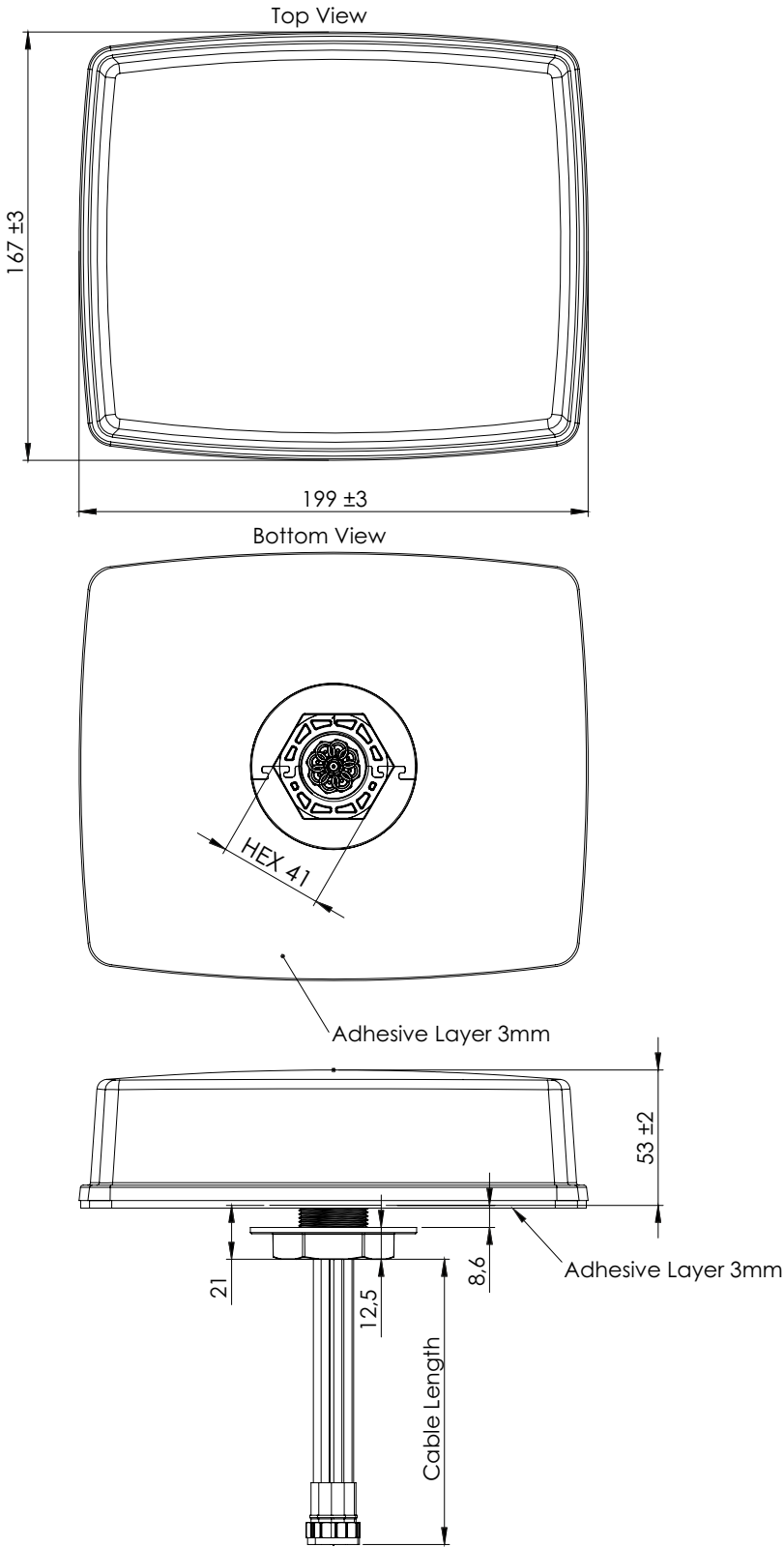

Screw Mount specs:  
**Mounting hole: Ø27.5mm**  
**Mounting torque: 6 Nm**  
**Surface thickness: max 8.6mm**  
**Wrench size: hex. 41mm**  
 Note: Dimensions are in millimeters  
 \*Dimensions are after mounting

5. Antenna Images

