

SPC-618WE

18.5" FHD TFT LED LCD Touch Panel Computer with 13th Gen. Intel® Core™ with ATEX Explosion-Protected certification

Preliminary



Features

- Industrial-grade 18.5" FHD TFT LCD with 50K lifetime and LED backlight
- 13th Gen. Intel® Core™ i7-1365URE deca-core processor
- Built in single DDR5 4800 RAM with 32GB capacity
- Built in sTLC SSD of 256GB with extreme longevity and reliability
- Compact, fanless embedded system with aluminum alloy front bezel and chassis grounding protection
- Specialized enhanced impact proof touchscreen with PCAP touch control and IP66-rated front panel
- Diverse system including Type C connector with USB 3.2, DP 1.4a, 15W power delivery
- Support TPM2.0 hardware security
- IEC Ex & ATEX certification for Zone 2/22 criteria

Introduction

Advantech's SPC-618WE Explosion-Protected Touch panel computer, is powered by Intel 13th Generation Intel Core processors. With its fan-less design, SPC-618WE delivers high performance that not simply meets customer demands for a daily-operation control panel, but a genuine Industry 4.0-era-tailored Industrial PC that features bountiful I/Os including two USB 3.2 ports, one USB-C port, expansions with sTLC Solid State Drive and WiFi module that support for ultra speed data transmission. The system was both IP66 and IEC Ex/ATEX Zone 2/22 Explosion-Protected certified, therefore is suitable for hazardous environment.

Specifications

General

- BIOS**: AMI UEFI
- Certification**: BSMI, CCC, CE, FCC Class A, ATEX Explosion Proof
- Cooling System**: Fanless design
- Dimensions (W x H x D)**: 479.3 x 300.3 x 80 mm
- Enclosure**: Front bezel: Die cast aluminum alloy
Back housing: Die cast aluminum alloy
- Mounting**: VESA Mount, Desktop, Wall or Panel Mount
- OS Support**: Windows 10
- Security**: TPM 2.0 (built-in)
- Power Consumption**: Typ. 46W; Max. 82W
- Power Input**: 19 - 24 V_{DC} ± 15%
- Watchdog Timer**: 15-255 sec (system)
- Weight (Net)**: 6KG

System Hardware

- CPU**: 13th Gen. Intel® Core™ i7-1365URE 1.7 GHz Deca-core processor
- Memory**: Single DDR5 4800 SO-DIMM RAM 32Gb
- LAN**: 2 x 2.5 GbE with Intel® i226
- Storage**: 1x M.2 2280
sTLC Solid State Drive 256 GB (Baseline)
sTLC Solid State Drive 512 GB (Option for custom model*)
1 x 2.5 SATA
sTLC Solid State Drive 256 GB (Option for custom model*)
sTLC Solid State Drive 512 GB (Option for custom model*)

*Detailed information listed in "Expansion Component for Custom Model"

- I/O**: 1 x Displayport 1.4a (Video output)
1 x Type C (USB 3.2 Gen.2, DP 1.4a, 5V w/ 3A max)
2 x USB 3.2 (Gen.1)
4 x USB 2.0
2 x RS-232/422/485
(Optional) 2 x 4Ω Speaker for Audio out

LCD Display

- Display Type**: FHD TFT LED LCD
- Display Size**: 18.5"
- Max. Resolution**: 1920 x 1080
- Max Colour**: 16.7M
- Luminance cd/m²**: 350 cd/m²
- Viewing Angle (H/V°)**: 178°/178°
- Backlight Life**: 50,000 hrs
- Contrast Ratio**: 1000:1

Touchscreen

- Light Transmission**: Above 85%
- Resolution**: Linearity
- Type**: PCAP touch screen

Environment

- Humidity**: 95% RH @ 40°C, non-condensing
- Ingress Protection**: IP66-rated front panel
- Operating Temperature**: -20~60 °C (-4~140 °F) (w/o air flow)
- Storage Temperature**: -20~60 °C (-4~140 °F)
- Vibration Protection**: With SSD: 1 Grms (5 ~ 500 Hz) (Operating, random vibration)

Rear View

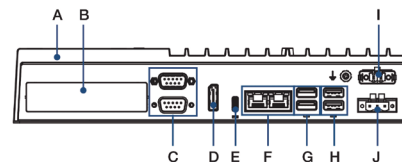

- A. Baseline Configuration
- B. iDoor slot
- C. RS-232/422/485
- D. Display Port
- E. TYPE-C
- F. 2.5GbE LAN port
- G. USB 3.2
- H. USB 2.0
- I. Remote Button
- J. DC

Dimensions

Unit: mm

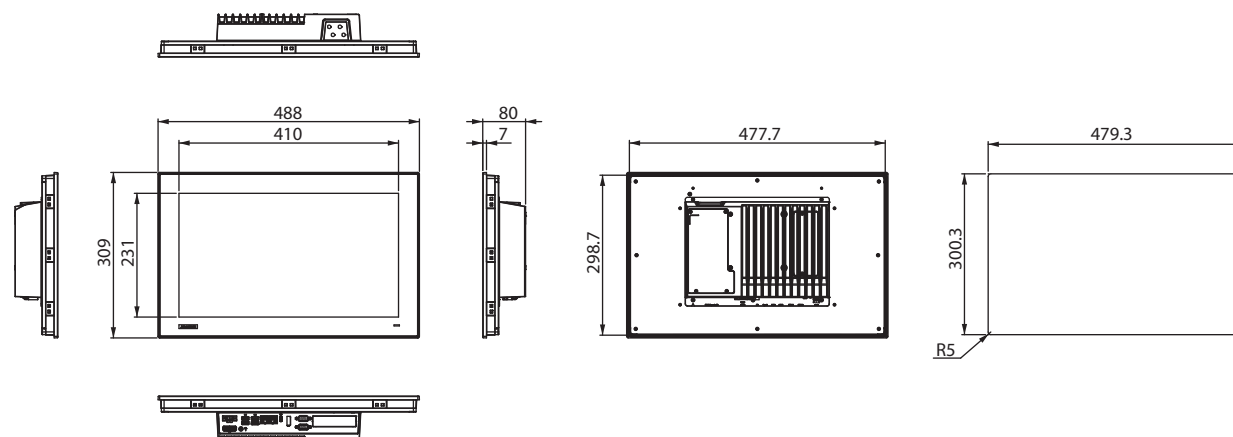

Panel Cut-out Dimensions: 479.3 x 300.3mm (18.87 x 11.82 in)

Ordering Information

- **SPC-618WE-PUD75A** 18.5" FHD Panel PC, ATEX Explosion-Protected certification, 13th Gen. Intel® i7-1365URE 1.7 GHz Deca-core processor

Embedded OS

- **20701WX1HS0009** Win10 LTSC for TPC-B520-D70AE

Optional Accessories

- **96PSA-A150W24T2-4** 150W 24V_{DC} power supply
- **1702002600** Power cable (US) 1.8 M
- **1702002605** Power cable (EU) 1.8 M
- **1702031801** Power cable (UK) 1.8 M
- **1700000596-11** Power cable (China/Australia) 1.8 M

Expansion Component for Custom Model

| ATEX Certified Expansion Components | | Description |
|-------------------------------------|--------------------|---|
| M.2 2280 SSD (Baseline) | SQF-S8BZ4-256GDSDE | SQF M.2 2280 SSD 256GB 3D sTLC |
| Option1 | SQF-S8BZ4-512GDSDE | SQF M.2 2280 SSD 512GB 3D sTLC |
| 2.5" SATA SSD (Baseline) | None | None |
| Option1 | SQF-S25Z4-256GDSDE | SQF 2.5" SATA SSD 256GB 3D sTLC |
| Option2 | SQF-S25Z4-512GDSDE | SQF 2.5" SATA SSD 512GB 3D sTLC |
| Wi-Fi Module (Baseline)* | None | None |
| Option1 | EWM-W165M203E | Wi-Fi 6 + BT Module 2.4/5/6GHz M.2 2230 |

*Wi-Fi Module may require wireless certification in specific region

Packing List

| Item | Part No. | Description | Qty |
|-----------------|---------------|--|-----|
| Grounding cable | 1703011001-11 | A Cable G-TEM 4.3 100CM C=GR/Y | 1 |
| Plug-In Block | 1652007930-01 | Plug-In Block 1x3P/5.08mm/PA66/F/VA | 1 |
| Warranty | 2190000902 | CARDBOARD-WARRANTY REV. A2 | 1 |
| VESA Screw | 1930005204 | Screw M4x10L R/S DH=6.8x2.50 + ST ZBK PL | 4 |
| China RoHS | 202KAKMC00 | China rohs for AKMC model name 1st ed | 1 |

Please contact Advantech for certificate compliance.