

FWA-1010VC

Universal Network Appliance for vE-CPE and SD-WAN



Highlights

- Industry-standard, off-the-shelf x86 server platform for remote office, and small to medium enterprise installations
- Dual 1GbE RJ45 or SFP auto-negotiation link for WAN connectivity
- Enhanced design to optimize system performance via integrated offload technology
- Optional 3G, 4G LTE and WiFi connectivity for deployment flexibility
- Tested and Certified by key software vendors for universal vE-CPE and SD-WAN roll-out

Overview

The FWA-1010VC is an off-the-shelf customer premise equipment (CPE) platform based on Intel x86 architecture optimized for deploying virtual network functions (VNFs) and services in small to medium enterprise businesses. The platform is primarily destined for communication service providers (CSPs) and enterprises leveraging the advantages of NFV (Network Function Virtualization) and SDN to replace fixed function systems with an open platform running these functions as VNFs.

While legacy networking solutions consist of tightly integrated hardware and software from a single supplier, NFV-based vE-CPE allows for a logical and flexible separation of hardware and software. The vertical silos with vendor lock-in are transformed into a horizontal mix-and-match approach that Advantech and key software partners are embracing to allow customers gain maximum flexibility by procuring hardware and software separately.

NFV based software solutions and vE-CPE equipment offer substantial CapEx and OpEx savings by replacing multiple special purpose appliances with a single platform. They also greatly enhance operational flexibility by enabling new and scaled-out services without the need for truck rolls. For example, a CSP can easily close security gaps by updating a firewall service remotely, add virus protection, and spin up a WAN optimization service, all through remote orchestration and without the need to install more hardware. Service deployment cycles can thus be collapsed from months to hours, encouraging CSPs and enterprises alike to deploy these technologies faster to gain an early competitive advantage and reap operational benefits sooner.

Together with tested and certified solutions from key NFV software vendors, Advantech supplies FWA-1010VC network appliances that have been profiled for exact performance and feature sets and are ready for deployment on customer premises.

Available as an Advantech branded or customer branded box, Advantech offers extensive integration and test services prior to packaging and labelling, all according to CSP specifications and software options. A worldwide logistics offers a flexible delivery model to meet unique needs. Advantech simplifies both delivery and replacement logistics so that service providers can bring final products to market on time.

Device Overview



Figure 1: FWA-1010VC Front view

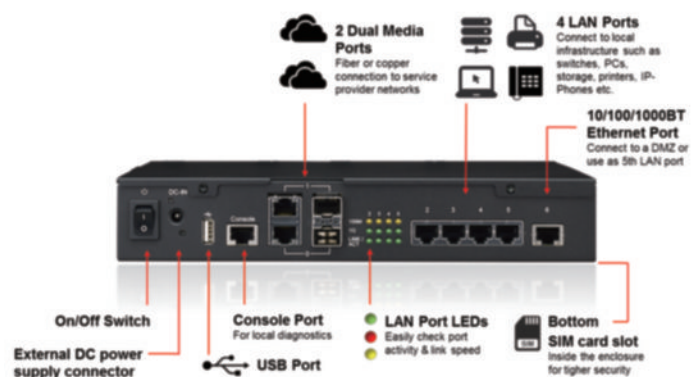

Figure 2: FWA-1010VC Connectivity

Product Summary

The FWA-1010VC is the entry-level model in Advantech's vE-CPE range and is based on the Intel® Atom™ Processor C2000 System-on-Chip (SoC) specifically designed for communications workloads. The following table provides a summary of the product features

Product Features

		FWA-1010VC-4CA2S	FWA-1010VC-8CA2S
CPU ^{Note1}	Number	Intel® Atom™ Processor C2558	Intel® Atom™ Processor C2758
	Core Count	4	8
	Frequency	2.4GHz	2.4GHz
	L2 Cache	2MB	4MB
DRAM	Socket	2x DDR3/DDR3L UDIMM slots, up to 1600MHz	
	Max. Capacity	16GB per socket and 32GB per system	
	ECC	Non-ECC or ECC	
Storage	2.5" SSD	None	1x 2.5" SATA3.0 Gen3 bracket
	M.2 SSD	1x M.2 2280 slot (option 2x M.2 2242 slots)	
Ethernet Interface		2x 10/100/1000BASE-T RJ45 or SFP auto-negotiation link by Marvell 88E1112 1x 10/100/1000BASE-T RJ45 port by Marvell 88E1112 4x 10/100/1000BASE-T RJ45 ports by Marvell 88E6141 with 1GbE uplink to CPU All ports support server class virtualization with 8 queues per port (VMDq)	
Expansion ^{Note2}		1x Full-sized Mini-PCIe slot with SIM socket for 3G/4G LTE module with 2x Antenna holes 1x M.2 2232 slot for WiFi module with 2x Antenna holes	
Other Interface	Front Indicator	Power, HDD, LTE, WiFi, SW defined status	
	Front Button	1x Software definable button	
	Rear I/O	1x USB2.0 Type A host port 1x RS232 Console port 1x Power Switch	
Thermal		1x system FAN with smart FAN feature for maximum 37.5dB(A)	
Power Input	Wattage	12V 5A, 60W external adaptor	
	Input	100 V ~ 240 V	
Environment		Operating	Non-Operating
	Temperature	0 ~ 40 °C (32 ~ 104 °F)	-20 ~ 80° C (-4 ~ 167° F)
	Humidity	5 ~ 85 %	5 ~ 95 %
Mechanical	Physical Dimension (W x L x H)	250 x 190.4 x 44 mm (9.8" x 7.5" x 1.7")	
	Mounting	Support desktop/Rack/Wall-mounting options	
	Weight	2.2 Kg (4.8lb)	2.3 Kg (4.8lb)
OS Support		Linux (CentOS, Red Hat, Ubuntu)	
Advantech S/W Packages		QSI (Linux based Advantech Bring-Up Image) DUI (Offline Diagnostics)	
Certification		CE/FCC Class B(without RF), CCC, CB, UL: FWA-1010VC barebone only	
3rd party SW		Please contact your Advantech representative for a list of the latest certified solution packages & VNFs	
Optional Accessory		Console cable 4G LTE Module kit(Sierra MC7455 for up to 300Mbps download and 50Mbps uplink speed) WiFi Module kit(Advantech EWM-W162M for IEEE 802.11ac/a/b/g/c 2x2 MIMO WLAN) Wall-Mount Kit Rack-Mount Kit Regional Power Cord	

Note1: Various system configurations and alternative Intel® Atom™ C2000 processor support are available and can be provided on request

Features and Benefits

Scalability and performance

The FWA-1010VC is available in Intel® Atom™ Processor for server configurations, ensuring that the right performance level can be matched to the workload at hand. Support for DPDK on all network interfaces provides up to 10x in packet throughput.

Rich LAN connectivity

2x GbE ports support copper as well as SFP deliver flexibility in connecting to existing on-premise infrastructure without external media converters.

4x integrated copper ports support auto crossover cabling (MDX) are connected to an integrated switch which not only saves the complexity of an extra switch but also frees up valuable CPU cycles for better application performance as LAN-to-LAN traffic is handled by the hardware switch.

An additional 10/100/1000Base-T Ethernet port can be used for additional LAN connectivity or the implementation of a DMZ.

FWA-1010VC has the ability to connect MPLS interface via 3G/4G module. This allows Hybrid / SD-WAN like services to perform traffic management. Integration with WiFi module with 2x2 MIMO support provides access point functionality.

Reliability & Availability

The FWA-1010VC comes with ECC memory capability as an essential feature for server reliability. In data centers, cloud and enterprise IT infrastructure, ECC support has been mandatory for decades. As such, Advantech's FWA-1010VC supports this feature as it is a crucial element in providing enterprise customers with stringent SLAs.

Secure connections without penalties

Integrated Intel® QuickAssist Technology accelerates execution of crypto algorithms without burdening the CPU. As a result, secure branch connectivity including end-to-end encryption can be provided without compromising VNF performance or increasing cost.

An integrated Trusted Platform Module (TPM) acts as a root of trust and can be used for secure key storage.

Physical Security

In deployment scenarios using wireless connectivity via the integrated modem socket, the SIM card can be inserted via a small, removable plate. The simple installation procedure can be handled by untrained users. In contrast to externally attached wireless dongles, it also secures the SIM card with the unit to avoid unwanted removal which would result in end customer service interruptions and increased support efforts for the service provider.

Agility and TCO

Dual-media WAN, 3G/4G, WiFi connectivity and copper LAN ports support allows the FWA-1010VC to span complete rollouts no matter which infrastructure is present in a given location. This helps to not only streamline logistics and service models but also to offer significant benefits in terms of life-cycle management and total cost of ownership.

Deployment Examples

Remote Office / Home Office: All-in-one integration

The FWA-1010VC can easily replace multiple devices in small offices: The four switch-based LAN ports can be used to connect local devices such as computers, printers and network attached storage systems directly. The integrated switch separates LAN-to-LAN traffic from LAN-to-WAN traffic yielding less strain on the processor for software-based switching.

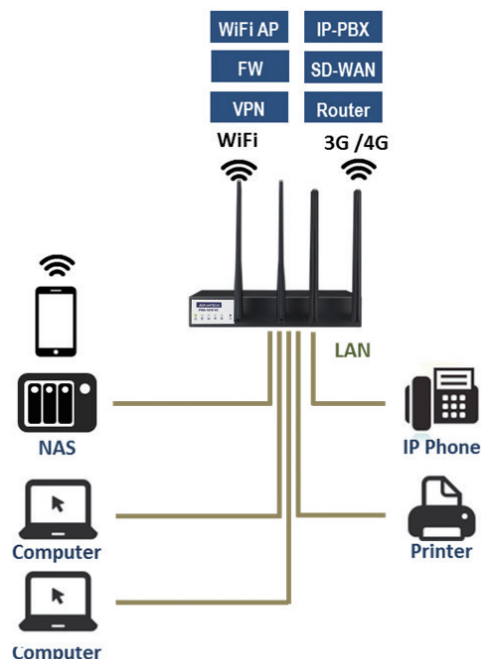

Figure 3 Remote Office / Home Office: All-in-one integration

The copper access port can be used to connect an IP Phone via a separate subnet simplifying QoS management for voice services.

Additional computers and portable devices such as smartphones and tablets can connect via the integrated WiFi access point. This high level of integration not only provides CAPEX benefits, but also optimizes operating expenses by reducing the number of on-premise devices to one for managed services and infrastructure/network as a service application.

Small & Medium Office: Integration with Existing Infrastructure

Small and medium offices may already utilize existing network infrastructure. In such scenarios, the FWA-1010VC typically connects to the LAN via an external switch using one of the device's LAN ports. The copper access port can be used for interfacing to a local administration station via a management LAN or demilitarized zone (DMZ).

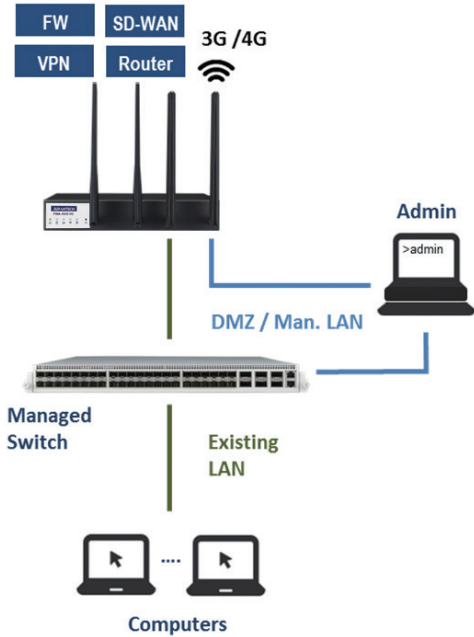

Figure 4 Small & Medium Office: Integration with Existing Infrastructure

Branch Security and XaaS Gateway

Enterprises looking for higher performance branch connectivity at lower cost may engage with additional service providers for direct connection to the internet and/or cloud networks. In this multi-service provider approach, an existing legacy router may be used to connect to the carrier network, for example for MPLS implementations.

SD-WAN software deployed on the vE-CPE appliance provides application-aware traffic routing and control. SD-WAN and application awareness also provides the foundation for applying specific security policies and service chains as traffic is routed over fairly secure carrier networks or comparably insecure connections to the internet for optimum utilization and throughput at lowest latency. Internet traffic may be passed through a stateful firewall, an anti-virus function and a web application firewall for content and URL filtering. Email traffic may only pass through the firewall and the anti-virus solution. ERP data on the other hand may only pass through the carrier network over a VPN, and simply require basic security handling. Best of all, with SD-WAN and NFV technologies, policies can easily be changed on the fly, and capacities scaled up and down without requiring any truck rolls.

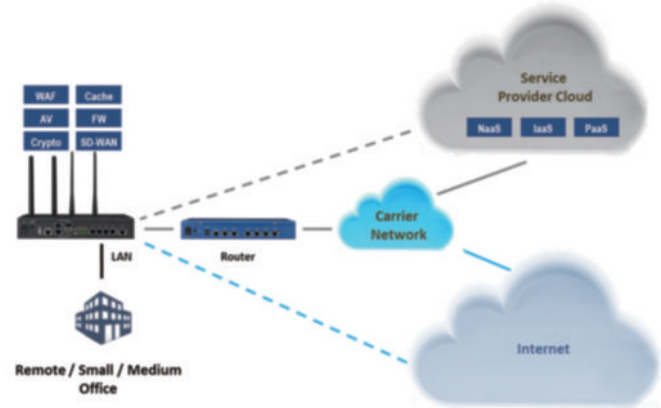

Figure 6 Branch Security and XaaS Gateway

Cloud-centric Deployments: Slim CPE

An alternative topology for vE-CPE and SD-WAN deployments is to use a slim device on premise that provides routing and secure connectivity to the carrier network. Additional network functions are hosted in the carrier network on scale-out platforms such as Advantech's PAC-6009 Carrier Grade NFVI platform, which is optimized for edge deployments

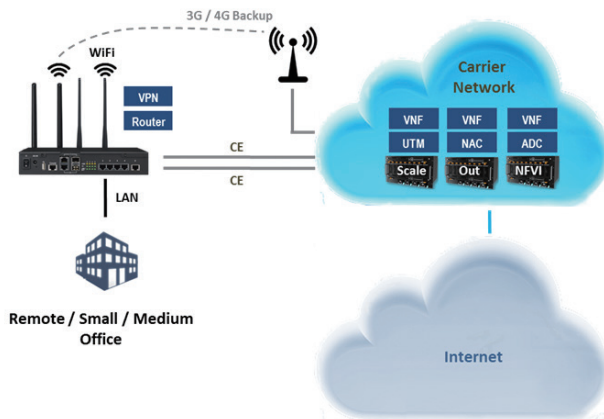

Figure 5 Cloud-centric Deployments: Slim CPE

Anything-as-a-Service (XaaS) providers may deploy a secure cloud gateway to not only direct branch traffic between existing legacy networks and their cloud environment. The cloud gateway can also provide secure cloud connectivity via protocols such as IPsec and TLS. Sensitive customer data that is to be stored or backed-up in the cloud can be fully encrypted before leaving the customer's premises while non-sensitive data may be passed through without consuming extra system bandwidth. Caching of frequently used data can also improve application performance and user experience.