

EKI-6333AC-1GPO Series

Industrial IEEE 802.11 a/b/g/n/ac Wi-Fi AP



Features

- Supports 802.11ac MIMO 2x2
- Supports wave 2 MU-MIMO that improves performance and expands user capacities
- WLAN transmission rate up to 867 Mbps
- Supports secure access with WEP, 802.1x, WPA/WPA2-Personal, WPA/WPA2-Enterprise
- Provides Web-based configuration
- Supports dual bands 2.4/5GHz concurrent
- IP67-rated waterproof & dustproof housing that withstands harsh environments

Introduction

The EKI-6333AC-1GPO is a feature-rich wireless AP providing reliable wireless connectivity for industrial environments. EKI-6333AC-1GPO improves the reliability of wireless connectivity, especially in applications requiring high reliability and throughput data transmission. To secure the wireless connection, EKI-6333AC-1GPO implements the latest encryption technologies, including WPA2/WPA/802.1x for powerful security authentication.

Specifications

Ethernet Communications

- **Port Type** RJ45
- **No. of Ports** 1
- **Interface** 1 x 10/100/1000 Base-T

Wireless LAN Communications

- **Compatibility** 2.4GHz: IEEE 802.11 b/g/n
5GHz: IEEE 802.11 a/n/ac
- **Speed** 2.4GHz: 300Mbps(Max), 5GHz: 867Mbps(Max)
- **Network Mode** Infrastructure
- **Free Space Range** Open space 100 m
Wireless Security WEP, WPA/WPA2-Personal, WPA/WPA2-Enterprise

Software

- **Management** Telnet, FTP, SNMP, Web UI, SSH
- **Wireless** Radio on/off, WMM, Output Power Control, Beacon Interval, RTS/CTS threshold, DTIM Interval
- **Operation Modes** Access Point mode, Client, Repeater
- **Configuration** Web Browser
- **Protocol** ARP, ICMP, IPv4, IPv6, TCP, UDP, DHCP Client, DHCP Server, Auto IP, Telnet, DNS, SNMP, HTTP, DMZ, PPPoE, VPN Passthrough, Telnet Server, SSH Server, FTP Server, QoS

Accessory Content

- Poll & Wall mounting kit
- Screw set
- External antenna x4

Antenna

- Default with 4 x external 5 dBi Omni antenna

Data Rates

- **802.11b** 11M, 5.5M, 2M, 1Mbps
- **802.11a/g** 54M, 48M, 36M, 18M, 12M, 9M, 6Mbps
- **802.11n** HT20 MCS0-15 / HT40 MCS0-15
- **802.11ac** VHT80 MCS0-9

Mechanics

- **Enclosure** Plastic
- **Mounting** Wall, Pole
- **Dimensions (W x H x D)** 111.2 x 173.6x 30.29 mm (4.37" x 6.83" x 1.19")
- **Weight** 316g

General

- **LED Indicators** System: Power
WLAN: Link/Active
LAN: Link/Active

Power Requirements

- **Power Input** 802.3af/at Compliance Source
- **Power Connector** PoE Adapter
- **Power Connector** RJ45
- **Power Consumption** 12.6W

Environment

- **IP Rating** IP67
- **Operating Temperature** -20 ~ 60 °C (-4~140°F)
- **Storage Temperature** -40°C to 80°C (-40°F to 176°F)
- **Operating Humidity** 10 ~ 90% RH

Regulatory Approvals

- TELEC

Dimensions

Unit: mm [inch]

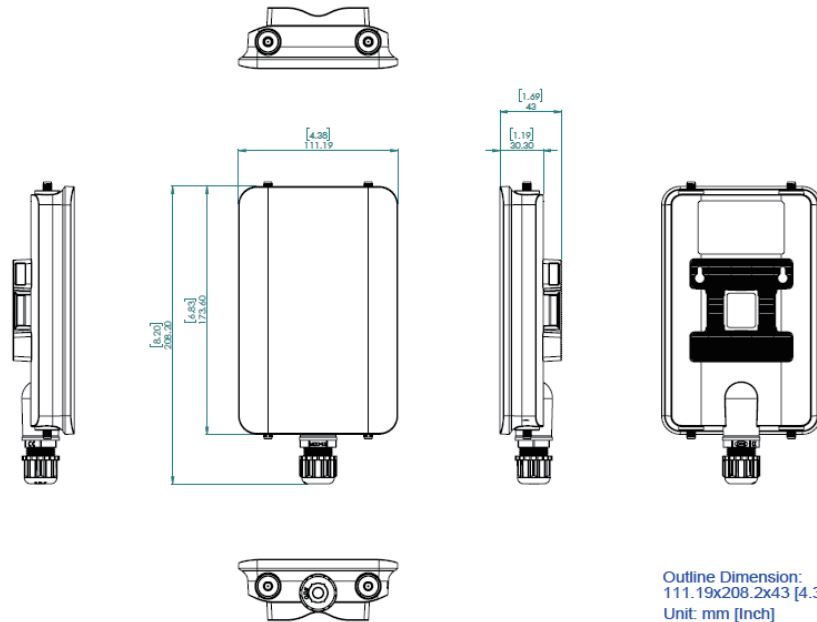

Outline Dimension:
111.19x208.2x43 [4.38x8.2x1.69]
Unit: mm [inch]

Wireless Transmission Rates

- **Transmitted Power***
 - 802.11a: 23 dBm@6Mbps
 - 802.11b: 23 dBm
 - 802.11g: 23 dBm@6Mbps
 - 802.11n HT20(2.4GHz): 23 dBm@ MCS 0/8
 - 802.11n HT40(2.4GHz): 23 dBm@ MCS 0/8
 - 802.11n HT20(5GHz): 23 dBm@ MCS 0/8
 - 802.11n HT40(5GHz): 23 dBm@ MCS 0/8
 - 802.11ac VHT80: 23 dBm @ MC 0
- **Receiver Sensitivity**
 - 802.11a: -89 dBm@6Mbps, -71 dBm@54Mbps
 - 802.11b: -92 dBm@1Mbps, -84 dBm@11Mbps
 - 802.11g: -89 dBm@6Mbps, -72 dBm@54Mbps
 - 802.11n HT20(2.4GHz): -87 dBm@MCS 0/8, -67 dBm@MCS 7/15
 - 802.11n HT40(2.4GHz): -84 dBm@MCS 0/8, -66 dBm@MCS 7/15
 - 802.11n HT20(5GHz): -89 dBm@MCS 0/8, -68 dBm@MCS 7/15
 - 802.11n HT40(5GHz): -86 dBm@MCS 0/8, -66 dBm@MCS 7/15
 - 802.11ac VHT80 -83dBm @MCS0; -56 dBm @MCS9

*Note: The listed value is the target power calibrated in the card. The actual power will vary depending on each country's regulation

Ordering Information

- **EKI-6333AC-1GPO-JA** 802.11 a/b/g/n/ac Wireless AP/Client