

IMF2100 Series DIN-Rail Serial to Fiber MODEM Quick Installation Guide

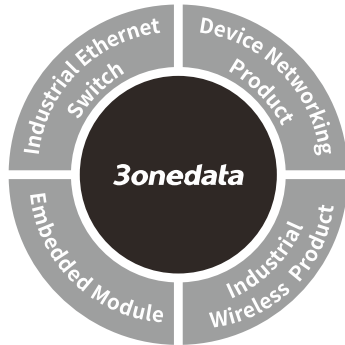

3onedata Co., Ltd.

Address: 3/B, Zone 1, Baiwangxin High Technology Industrial Park, Xili, Nanshan District, Shenzhen

Website: www.3onedata.com

Tel: +86 0755-26702688

Fax: +86 0755-26703485

【Package Checklist】

Please check whether the package and accessories are intact while using the device for the first time.

1. Serial to fiber MODEM
2. Quick installation guide
3. DIN-Rail mounting kit
4. Certification
5. Warranty card

If any of these items are damaged or lost, please contact our company or dealers, we will solve it ASAP.

【Product Overview】

The series products are serial port to fiber MODEM that convert RS-232/485/422 serial port signal to optical signal.

The model is:

- Model I IMF2100-1F-1DI(3IN1)-TB-P(12-48VDC) (1 fiber port + 1 RS-232/485/422 serial port with isolation + 1 12~48VDC power supply)
- Model II IMF2100-2F-1DI(3IN1)-TB-2P(12-48VDC) (2 fiber ports +1 RS-232/485/422 serial port with isolation + 2 12~48VDC power supply)
- Model III IMF2100-2F-1DI(3IN1)-TB-P(110-370VDC) (2 fiber ports + 1 RS-232/485/422 serial port with isolation + 1 110-370VDC power supply)
- Model IV IMF2100-1F-1DI(3IN1)-TB-P(85-265VAC) (1 fiber port + 1 RS-232/485/422 serial port with isolation + 1 85-265VAC power supply)
- Model V IMF2100-2F-1DI(3IN1)-TB-P(85-265VAC) (2 fiber ports + 1 RS-232/485/422 serial port with isolation + 1 85-265VAC power supply)

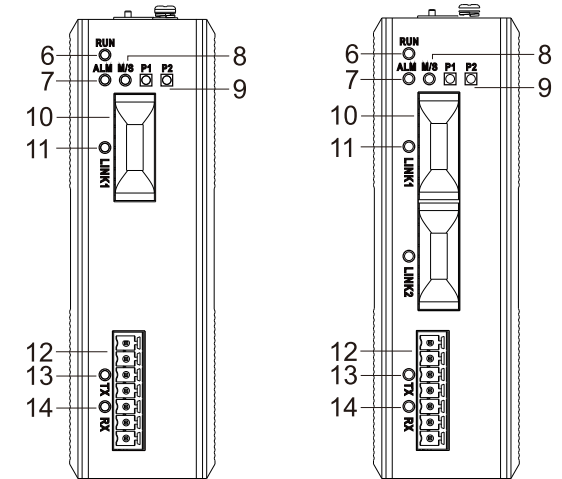

Model I, Model IV

Model III, Model V

【Panel Design of AC/DC Single Power Supply】

- Top view, bottom view and rear view

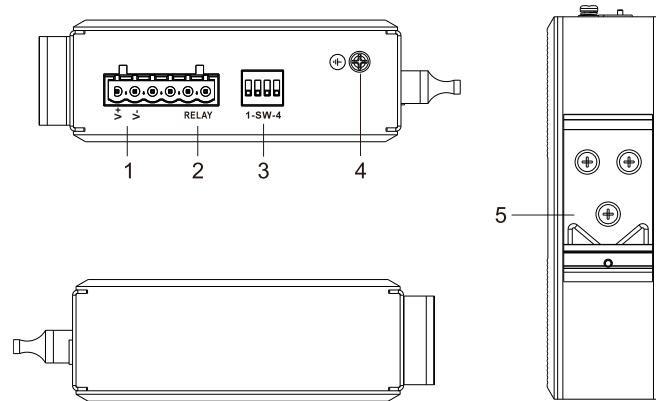

- Front view

【Panel Design of Dual Power Supply】

- Top view, bottom view and rear view

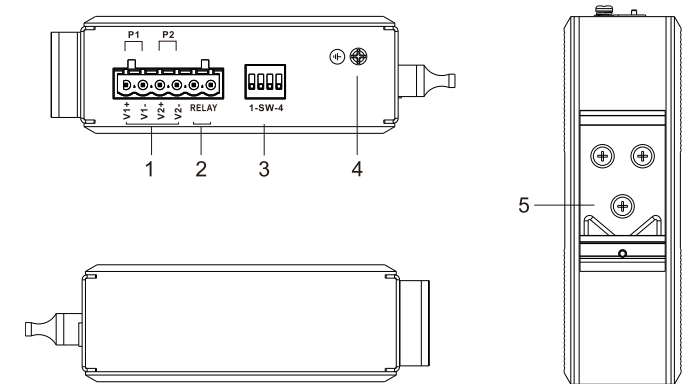

Model II

- Front view and Side View

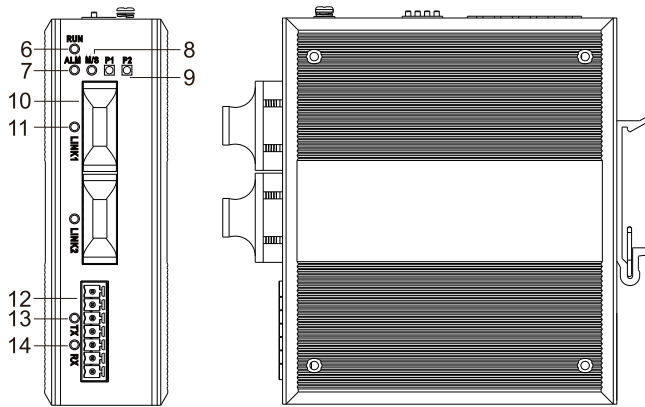

1. Power supply input terminal block
2. Relay output terminal block
3. DIP switch
4. Grounding screw
5. DIN-Rail mount
6. Ring network master/slave indicator
7. Alarm indicator
8. Running indicator
9. Power supply indicator
10. Fiber port
11. Fiber port indicator
12. RS-232/485/422 serial port
13. Serial port data transmitting indicator
14. Serial port data receiving indicator

【Mounting Dimension】

Unit: mm

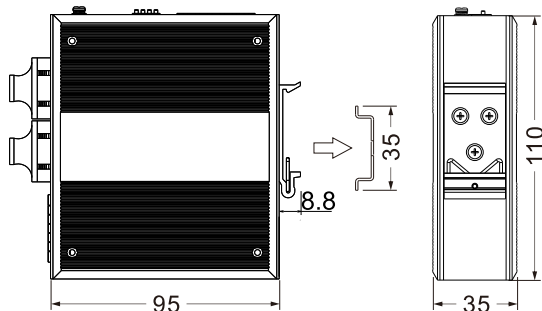

Notice before mounting:

- Don't place or install the device in area near water or moist, keep the relative humidity of the device surrounding between 5%~95% without condensation.
- Before power on, first confirm the supported power supply specification to avoid over-voltage damaging the device.
- The device surface temperature is high after running; please avoid direct contact in case of scalding.

【Mounting DIN-Rail】

For convenient usage in industrial environments, the product adopts 35mm DIN-Rail mounting, mounting steps as below:

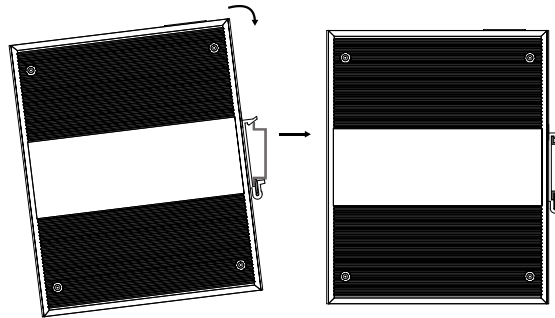

- Step 1 Check if the DIN-Rail mounting kit is installed firmly.
- Step 2 Insert the top of DIN-Rail mounting kit (one side with spring support) into DIN-Rail, and then insert the bottom into DIN-Rail.

Tips:

Insert a little to the top, push it down and then insert to the bottom.

- Step 3 Check and confirm the product is firmly installed on DIN-Rail, then mounting ends.

【Dismounting DIN-Rail】

- Step 1 Device power off.
- Step 2 After lift the device upward slightly, first shift out the bottom of DIN-Rail mounting kit, then shift out the top of DIN-Rail, disassembling ends.

【Connecting Power Supply】

The device provides 6-pin 5.08mm pitch terminal blocks on the top panel. This series provides 5 types of product which adopt different power supply ranges. Please notice the corresponding power supply type of the device in case of damaging the device.

➤ 12~48VDC DC power supply input

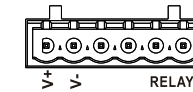

The power supply terminal blocks of Model I are V+ and V1-. Model II provides dual power supply, and its terminal blocks are V1+, V1-, V2+ and V2-. Power supply supports 2.0A built-in overcurrent protection, non-polarity. When power supply is connected oppositely or power failure occurs in any one of the two power supplies, the device can still operate normally.

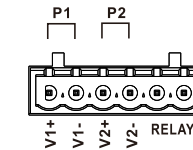

➤ 110~370VDC DC power supply input

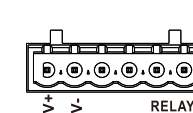

The power supply terminal blocks of Model III are V+ and V1-. Power supply supports 2.0A built-in overcurrent protection and non-polarity. The device can still operate normally when power supply is connected oppositely.

➤ 85~265VAC AC power supply input

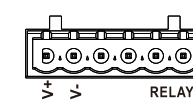

The power supply terminal blocks of Model IV and Model V are V+ and V1-. Power supply supports 2.0A built-in overcurrent protection.



Note:

- Power ON operation: First insert the power supply terminal block into the device power supply interface, and then plug the power supply plug contact and power on.
- Power OFF operation: first unpin the power plug, then remove the terminal block wiring part, please note the operation order above.
- Notice that the grounding screw on the shell should ground.

【Connecting Relay】

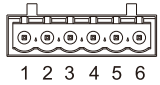

The device provides 6-pin 5.08mm pitch terminal blocks on the top panel, and the PIN5, PIN6 are used for relay output. Relay

terminals are a pair of normally close contacts of device alarm relay, which are closed when device powers off or in normal non-alarm state, opened when any alarm information occurs. When the fiber optics of the device disconnects or any one of the two power supplies fails, relay would send alert. It can be connected to alerting lamp, alarm buzzer, or other switching value collecting devices for timely warning operators when alarm information occurs.

【DIP Switch Setting】

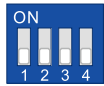

The device provides 4-pin DIP switch for function setting. Please power off and power on after changing the status of DIP switch.

The DIP switch definitions are as follows:

DIP	ON	OFF
1	The device is in MASTER status	The device is in SLAVE status
2	Enable 120Ω RS-485 terminal impedance	Disable 120Ω RS-485 terminal impedance
3	Enable power failure alarm	Disable power failure alarm
4	Enable fiber port disconnection alarm	Disable fiber port disconnection alarm

【Connecting Serial Port】



The device provides 1 RS-232/485/422 serial port. It supports RS232, RS485 and RS422 that cannot be used at the same time.

The interface type is 7-pin 3.81mm pitch spring-loaded terminals and its pin definitions are as follows:

PIN	1	2	3	4	5	6	7
RS-232	—	—	—	—	GND	TXD	RXD
RS-485	D+	D-	—	—	GND	—	—
RS-422	T+	T-	R+	R-	GND	—	—

【Checking LED Indicator】

The device provides LED indicators to monitor the operation status of device and fully simplify troubleshooting. The detailed status of each LED is described in the table as below:

LED	State	Description
M/S	ON	Device is the master device of the ring network
	OFF	Device is the slave device of the ring network
ALM	ON	Fiber port is disconnected or dual power supply device has power failure
	OFF	Alarm function isn't turned on or no alarm information
RUN	OFF/ON	Device runs abnormally or is not powered on
	Blinking	Device runs normally
P1/P2	ON	Power supply P1/P2 is connected normally
	OFF	Power supply P1/P2 is not connected or device is in abnormal state
LINK(1-2)	ON	Fiber port is connected
	OFF	Fiber port is not connected
	Blinking	Fiber port exists data transmission
RX	Blinking	Serial port is receiving data
	OFF	Serial port is not receiving data
TX	Blinking	Serial port is transmitting data
	OFF	Serial port is not transmitting data

【Specification】

Standard	
Standard	EIA RS-232C, RS-485, RS-422
Interface	
Fiber port	Optional SC/FC/ST interface and single mode/ multimode

Serial port	Support 1 RS-232/485/422 serial port and adopt 7-pin 3.81mm pitch spring-loaded terminals
Relay	Support 1 relay alarm output, adopts 6-pin 5.08mm pitch terminals(relay occupies 2 pins), current load capacity is 1A@30VDC or 0.3A@125VAC
Indicator	Alarm indicator, running indicator, power supply indicator, fiber port connection indicator, Master/Slave indicator, serial port data receiving indicator, serial port data sending indicator
Power supply	
Input power supply	Optional 12~48VDC (dual power supply/single power supply), 110~370VDC or 85~265VAC
Input terminal blocks	6-pin 5.08mm pitch terminal blocks (single power supply occupies 2 pins or dual power supply occupies 4 pins), support built-in 2.0A over-current protection, DC power supply supports non-polarity
Power consumption	
No-load	≤3.0W @24VDC
Full-load	≤3.4W @24VDC
Operating environment	
Operating temperature	-40~75℃
Storage temperature	-40~85℃
Operating humidity	5%~95% (no condensation)
Protection grade	IP40